

***Thank you for your choice of HF inverter.  
Perfect quality and wholehearted service is guaranteed from  
Yantai Huifeng Electronics Co., Ltd.***

As a general series of top-quality, multifunction and low noise, F1500-G series inverter can meet your requirements for various applications.

This manual is to provide users with precautions on installation & debugging, parameter-setting, operation, trouble-diagnosing and daily maintenance. Please read it carefully before installation and using inverter for proper operation. This manual is provided together with inverter and should be kept properly for future use.

Indications for reading:



**Hazard! Improper installation or operation likely to cause human casualty or property loss.**



**Warning! Improper installation or operation likely to cause human casualty or property loss.**



**Warning! Improper operation likely to effect inverter performance**

**P××:** indicating the relevant page number

**MIN(a, b):** indicating the lower one of values a and b



**MAX(a, b):** indicating the higher one of values a and b

## CONTENTS

I. Operation in Safety .....	1
II. Products .....	3
2.1 Models & Nameplate .....	3
2.2 Products List .....	3
2.3 Appearance .....	5
2.4 Performance Indexes .....	6
III. Installation & Wiring .....	7
3.1 Installation .....	7
3.2 Wiring .....	9
IV. Operation & Display .....	16
4.1 Keypad Control Unit .....	16
4.2 Function Parameters Setting .....	18
4.3 Function Code Grouping .....	19
4.4 Panel Display .....	19
V. Functions & Parameters Instruction .....	20
5.1 Basic Parameters .....	20
5.2 Operation Control Parameters .....	24
5.3 Multi-Speed Parameters .....	30
5.4 Programmable Input & Output Terminal Parameters .....	33
5.5 V/F Control Parameters .....	36
5.6 PI Setting Parameters .....	39
5.7 Timing Control & Definable Protection Parameters .....	41
5.8 Analog signal Parameters .....	43
5.9 Communication Parameters .....	44
VI. Simple Mode of Operation .....	46
6.1 Operation Mode Block Diagram .....	46
6.2 Speed Control Mode .....	46
Appendix 1 Trouble Shooting .....	55

Appendix 2 Function-Codes Zoom Table.....58  
Appendix 3 Selection of Braking Resistor and Braking unit .....67

## I. Operation in Safety

 <b>Hazard!</b>
<ul style="list-style-type: none"> <li>★ Inverter is not allowed to install in a place with flammable or explosive gases in case explosion may be triggered off.</li> <li>★ Only competent professionals can handle installation, wiring, operation and maintenance on inverter.</li> <li>★ Inverter grounding terminal PE (  ) shall be well connected to earth (grounding impedance not more than 4Ω ).</li> <li>★ Shortcircuit is not allowed between common point (CM) and reference point (GND or AGND) for inverter's internal power supply and input zero line or inverter's own "N" terminal.</li> <li>★ Make sure that wiring is properly connected and cover-board is well fixed prior to inverter switch-on;</li> <li>★ Do not touch inveter's charged terminals with hands after it is switched on.</li> <li>★ Swich off before conducting any wiring or maintenance.</li> <li>★ No maintenance is allowed within the first 10 minutes after switch-off or when DC bus voltage exceeds 36V. Do not touch internal circuit or components.</li> </ul>
 <b>Warning!</b>
<ul style="list-style-type: none"> <li>★ Make sure for a proper input voltage with inverter before it is connected with power.</li> <li>★ Do not drop such metal objects as screwdriver or screw into inverter.</li> <li>★ Do not install inverter in a place with direct sunlight. Do not stem inverter's vent.</li> <li>★ Do not connect input power to Teminals U, V, W or PE, P, B (N).</li> <li>★ No direct connection of braking resistor to Terminal P or N.</li> <li>★ Control loop wiring shall be separate from power loop wiring to avoid possible interference.</li> </ul>



### Warning!

- ◆ Please read this manual carefully before any operation on inverter.
- ◆ Inverter should not be stored or installed where there is strong vibration, strong erosion, heavy dust, high temperature or greater humidity.
- ◆ Regular check shall be required for a proper wiring with inverter's input and output, and to make sure that the other wirings of the equipment are not aging.
- ◆ Check is required for motor insulation resistance before installation and operation.
- ◆ Extra cooling measures shall be necessary if motor often runs at low speed.
- ◆ Braking resistor or braking unit shall be adopted to avoid frequent over-voltage or over-current in case of negative-torque energy feedback.
- ◆ Neither variable resistor or capacitance should be connected to inverter's output to improve power factor. Do not install a breaker between inverter's output and motor. Should a breaker have to be installed, it shall be ensured that it works only when inverter output current reads

zero.

- ◆ F1500-G inverter has a safety level of IP20.
- ◆ Cleaning is recommended on inverter's internal components and radiator after it is in use for 1~3 months. Should it not be used for a long time, inverter should be switched on at a certain interval (better one month).

## II. Products

### 2.1 Models & Nameplate

Product model is interpreted as below (taking for instance the single-phase 1.5KW inverter with internal braking unit)

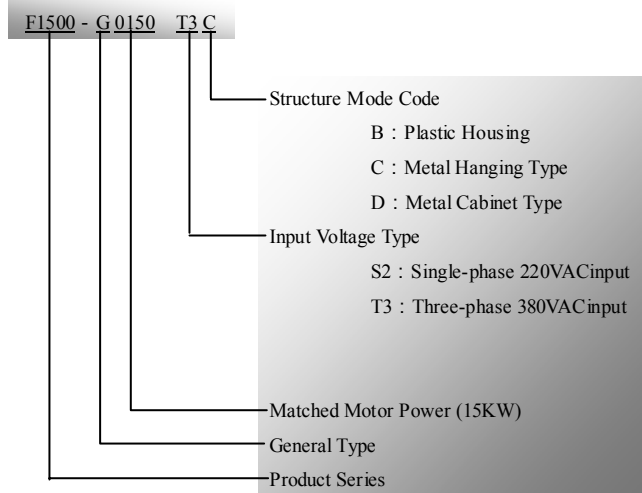

Fig 2-1 Product Model Illustration

F1500-G series inverter's nameplate is illustrated as Fig 2-2 (taking the three-phase 15KW inverter for instance).

AC: alternating current input.

3PH:three-phase input. 380V and 50/60Hz stands for rated input voltag e and frequency

3PH: three-phase output. 15KW and 32A stands for inverter's rated power and rated output current while 0 ~ 380V, inverter's output voltag e range.

0.00 ~ 400.0Hz: output frequency range

		HUIFENG ELECTRONICS CO.,LTD			
MODEL	F1500-G0150T3C				
INPUT	AC	3PH	380V	50/60HZ	
OUTPUT	3PH	15KW	32A	0-380V	
				0.00 - 400.0HZ	
CE					F 15G0150T3696000000
MADE IN CHINA					

Fig2-2 Nameplate Illustration

### 2.2 Product List

F1500-G series inverter's power range: 0.2 ~ 110KW. For main information, refer to Table 2-1.

For inverter's external dimensions and installation dimensions, please refer to 3.1.3 (P<sub>9</sub>).

Table 2-1 F1500-G Product List

Models	Rated Input Voltage ( V )	Rated Output Current (A)	Structure Code	Applicable Motor (KW)	Remarks
F1500-G0004S2B	~ 220 (single-phase)	2.5	B0	0.4	Single-Phase Inverter (without internal braking unit)
F1500-G0007S2B	~ 220 (single-phase)	4.5	B0	0.75	
F1500-G0015S2B	~ 220 (single-phase)	7.0	B2	1.5	
F1500-G0022S2B	~ 220 (single-phase)	10.0	B3	2.2	
F1500-G0007T3B	~ 380 (three-phase)	2.0	B2	0.75	Three-phase inverter (with internal braking unit)
F1500-G0015T3B	~ 380 (three-phase)	4.0	B2	1.5	
F1500-G0022T3B	~ 380 (three-phase)	6.5	B2	2.2	
F1500-G0037T3B	~ 380 (three-phase)	8.0	B4	3.7	
F1500-G0040T3B	~ 380 (three-phase)	9.0	B4	4.0	
F1500-G0055T3B	~ 380 (three-phase)	12.0	B5	5.5	
F1500-G0075T3B	~ 380 (three-phase)	17.0	B5	7.5	
F1500-G0110T3C	~ 380 (three-phase)	23	C1	11	
F1500-G0150T3C	~ 380 (three-phase)	32	C2	15	
F1500-G0185T3C	~ 380 (three-phase)	38	C3	18.5	
F1500-G0220T3C	~ 380 (three-phase)	44	C3	22	
F1500-G0300T3C	~ 380 (three-phase)	60	C4	30	three-phase inverter (without internal braking unit)
F1500-G0370T3C	~ 380 (three-phase)	75	C5	37	
F1500-G0450T3C	~ 380 (three-phase)	90	C5	45	
F1500-G0550T3C	~ 380 (three-phase)	110	C6	55	
F1500-G0750T3C	~ 380 (three-phase)	150	C6	75	

### 2.3 Product Appearance

Exterior structure of F1500 - G series inverter is classified into plastic and metal housings. Plastic housing is shaped by mould pressing with hi-quality polymeric carbon, nice and strong with good tenacity; metal housing adopts advanced process of exterior plastic powder spraying, glossy in color and elegant in appearance.

#### 2.3.1 Plastic Housing Appearance

Appearance and structure components are indicated as in Fig 2-3, taking F1500 - G0055T3B for an instance.

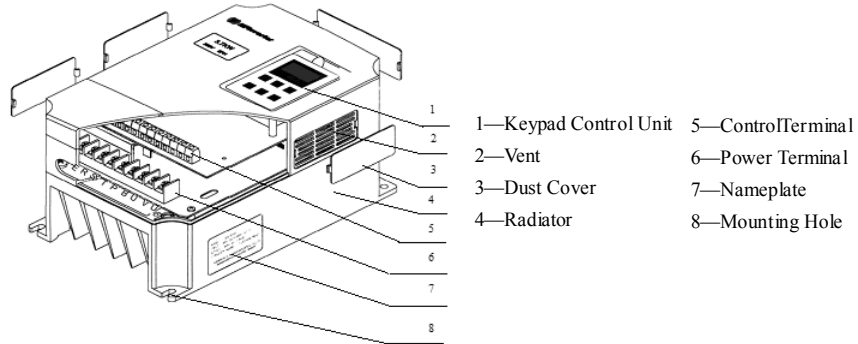

Fig 2-3 Plastic Housing

#### 2.3.2 Metal Housing Appearance

Appearance and structure components are indicated as in Fig 2-4, taking F1500 - G0220T3C for an instance. Detachable one-side door-hinge structure is adopted for front panel for a convenient wiring and maintenance.

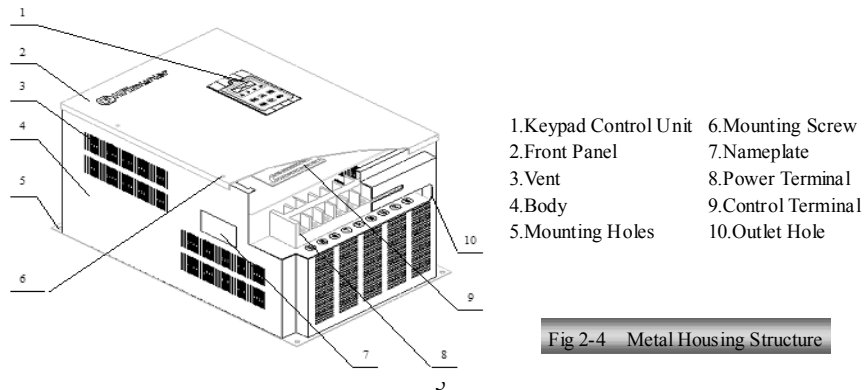

Fig 2-4 Metal Housing Structure



## 2.4 Performance Indexes

Items		Descriptions
Input	Rated Voltage	three-phase 380V±15% single-phase 220V±15% ( three-phase 220V±15% )
	Rated Frequency	50/60Hz ( ±5% )
Output	Rated Voltage	three-phase 0 ~ 380V; three-phase 0 ~ 220V
	Frequency Range	0.00 ~ 400.0Hz (frequency resolution ratio 0.01Hz)
	Overload Capacity	150% 60S
Control Mode	Frequency Setting Accuracy	Digit Setting: 0.01Hz, Analog signal Setting: Max Frequency×0.4%
	Setting Mode	optimized space vector control
	V/F Curve	3 kinds of V/F curves. To select and set beeline V/F curve, polygonal line V/F curve and square V/F curve as per load
	Torque Promotion	Manual setting torque promotion within 1 ~ 15%
	Automatic Voltage Setting	Automatic setting output voltage to meet input power fluctuation within certain range
	Braking Mode	DC Braking + Optimized Energy-consumption Braking
	PI Adjusting	With built-in PI adjuster for automatic control
	Jogging	Jogging Range: 0.00 ~ 400.0Hz
Operation Function	Frequency Setting	Digit frequency setting, keypad “▲ / ▼” keys setting, “UP” and “DOWN” terminals setting; Keypad potentiometer or external analog signal (0 ~ 10V, 0 ~ 20mA) setting; Analog channel compound operation setting; Multi-stage speed control and coding speed control; communication control box / computer setting.
	Start/Stop Control	Control over keypad, communication control box, terminals and computer
Protection Function	Input out-phase, input undervoltage, over-voltage, over-current, inverter overload, motor overload, overheat, current check trouble, peripheral equipment trouble, user password error/exterior interference, contactor monitoring.	

Display	LED nixie tube showing present output frequency, present rotate-speed, present output current, present output voltage, final axis linear-velocity, exterior pulse count-value, types of error, function-code parameters and operation parameters; 4 LED indicators showing the current working status of inverter.	
Environment Conditions	Equipment Location	Free of tangy caustic gases or dust
	Environment Temperature	-10℃ ~ +50℃
	Environment Humidity	Below 90% (no water-bead coagulation)
	Vibration Strength	Below 0.5g (acceleration)
	height above sea level	Below 1000 meters
Applicable Motor Power	0.4 ~ 75KW	

### III. Installation & Wiring

#### 3.1 Installation

##### 3.1.1 Installation Direction & Space

For better heat radiation of inverter, it should be installed perpendicularly ( as shown in Fig 3-1) while ventilation space shall be secured in the surroundings. For clearance dimensions for installation of inverter, refer to Table 3-1 (recommended).

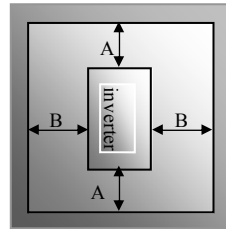

Hanging Type

Fig 3-1 Inverter Installation Illustration

Table 3-1 Clearance Dimensions

Inverter Type	Clearance Dimensions	
Hanging Type ( < 22KW )	A ≥ 150mm	B ≥ 50mm
Hanging Type ( ≥ 22KW )	A ≥ 200mm	B ≥ 75mm

**3.1.2 Installation Environment**

- ◆ No drenching, dripping, steam, dust or oily dust; no caustic, flammable gases, liquid; no metal particles or metal powder.
- ◆ Environment temperature: within -10°C ~ +50°C.
- ◆ Environment relative humidity: below 90%, without water-bead coagulation.
- ◆ No strong electromagnetic interference.
- ◆ Vibration strength: below 0.5g (acceleration).
- ◆ Ventilation should be secured should inverter be installed inside a control cabinet.

**3.1.3 External Dimensions & Installation Dimensions**

Table 3-2 F1500-G Product Dimension List

Structure Code	External Dimensions (A×B×H)	Installation Dimensions (W×L)	Mounting Screws	Remarks
B0	105×120×150	94×139	M4	Plastic Housing Hanging Type
B2	125×140×170	114×160	M5	
B3	143×148×200	132×187	M5	
B4	162×150×250	145×233	M5	
B5	200×160×300	182×282	M6	
C1	225×220×340	160×322	M6	Metal Hanging Type
C2	230×225×380	186×362	M6	
C3	265×235×435	235×412	M6	
C4	314×235×480	274×464	M6	
C5	360×265×555	320×530	M6	
C6	410×300×630	370×600	M10	

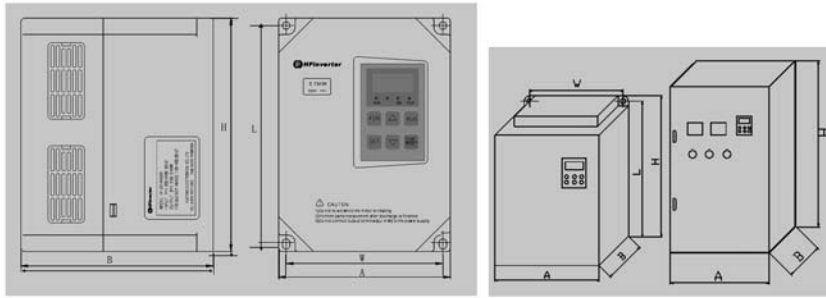

Fig 3-2 Dimension Code Illustration

## 3.2 Wiring

### 3.2.1 Standard Wiring Diagram



#### Warning!

- Control loop wiring shall be separate from main loop wiring, and should never be laid in the same wiring duct to avoid any possible interference.
- Control wiring should adopt shielded split-conductor, with section-area of  $0.3 \sim 0.5\text{mm}^2$  for Lead, but signal wire should not be too long.

Wiring mode for inverter's main loop and control loop are indicated as in the followings: Fig 3-3 standard wiring diagram for single-phase inverter (**including three-phase 220 VAC input inverter**). Fig 3-4 standard wiring diagram for three-phase inverter.

Note: Braking resistor and braking unit are both optional. Refer to Appendix 3 (P<sub>70</sub>) for standards of options.

Wiring Diagram 1

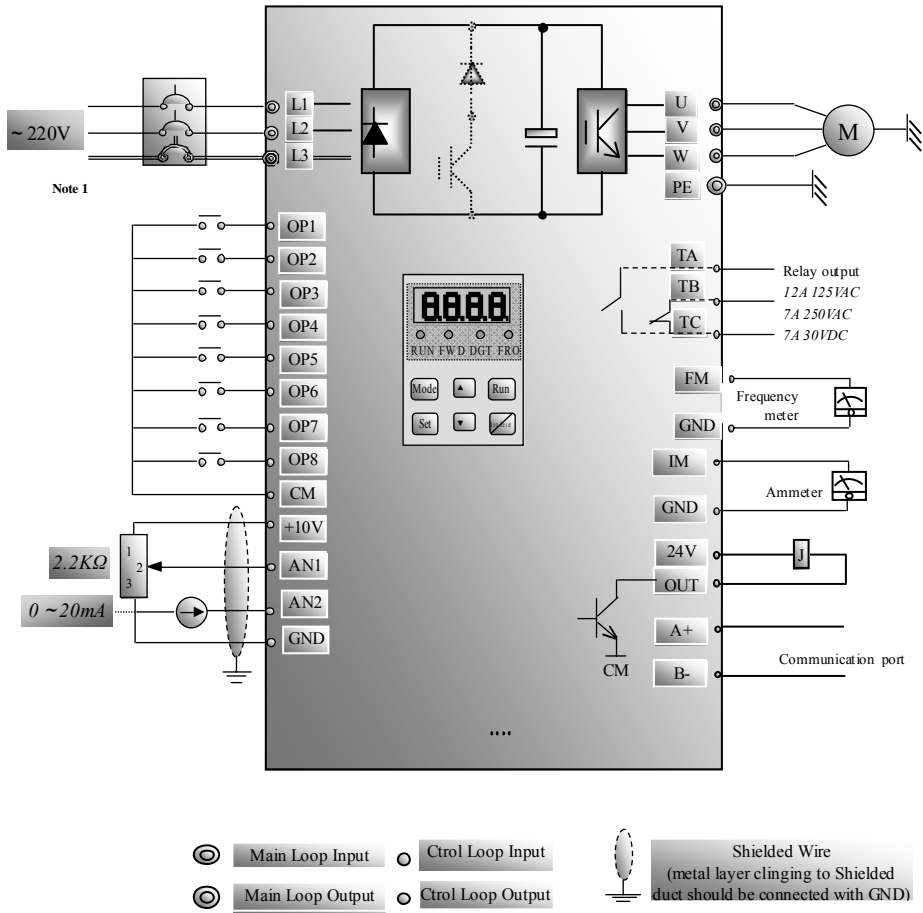

Fig 3-3 Standard Wiring Layout for Single-Phase Inverter

Wiring Diagram 2

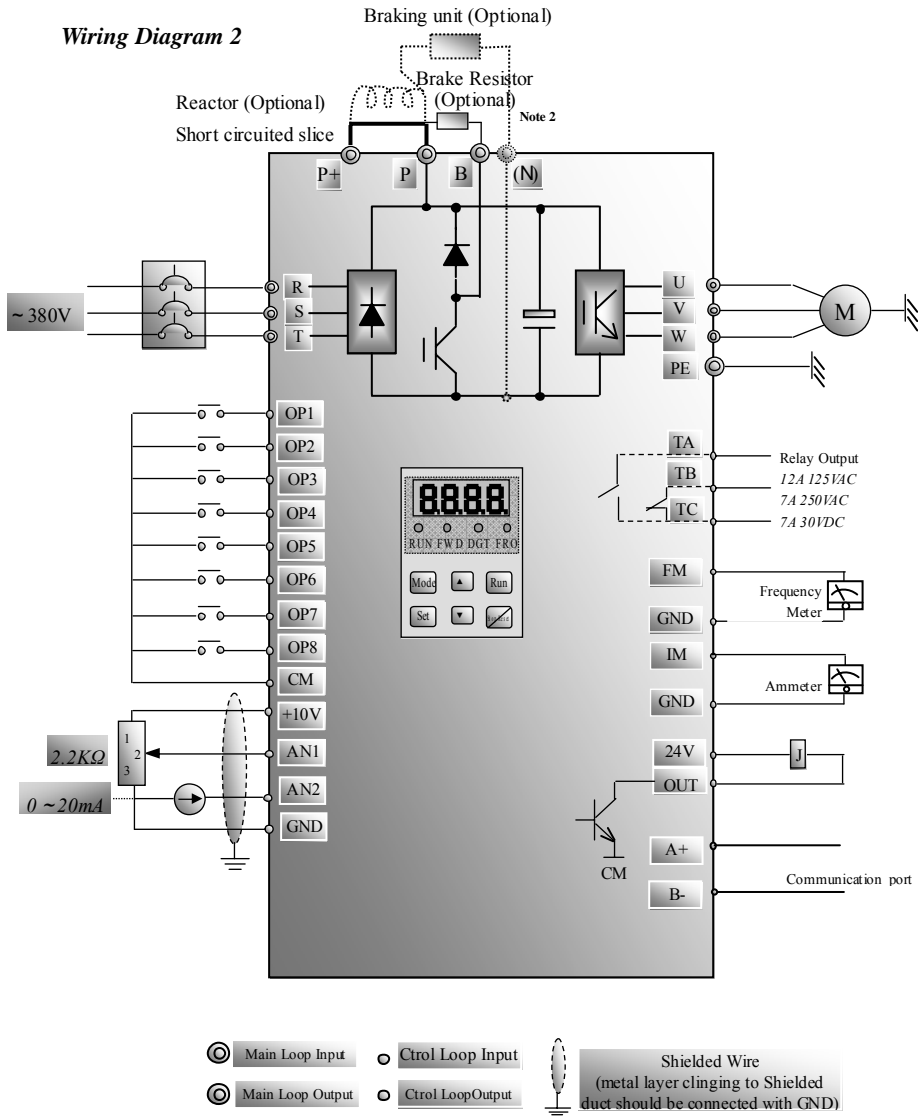

Fig 3-4 Standard Wiring Diagram for Three-Phase Inverter

**Notes:**

**Note 1.** Single-phase 220V inverter is only connected to L1 and L2.

**Note 2.** Terminals P and B in Wiring Diagram 2 are connected to braking resistor while Terminals P and N are connected to braking unit, Terminals P+ and P, to reactor, as per main loop terminals.

**3.2.2 Input & Output Terminals**

1) Power Terminals:

The wiring of power loop is very simple. R, S, T terminals of 3-phase inverter(R and T or L1and L2 of 1-phase inverter) shall be connected to power supply. PE(E) shall be connected to grounding. And U, V, W terminals shall be connected to motor. Motor must be grounding.

For 1-phase inverter, if the load is too heavy, the built-in braking unit can not meet the requirement. In this case, user should use external braking unit.

For 3-phase inverter with power lower than 15kw, there is built-in braking unit. If the load is not too heavy, user can only connect braking resistance to meet the braking requirement.

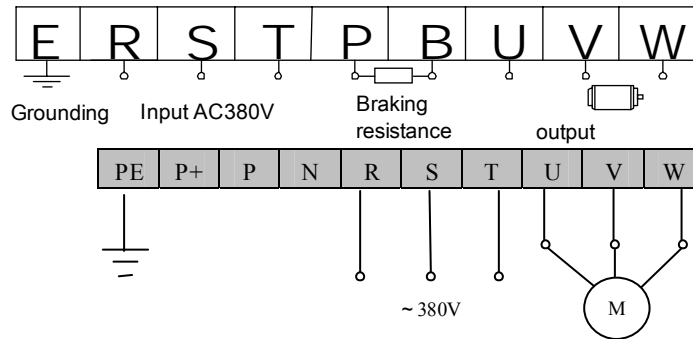

This figure is only a sketch map, maybe there is some difference from actual situation. Please refer to actual situation when inverter is used.

**Note:** The grounding mode of F1500-G0007T3B, 0015S2B, 0015T3B and 0022T3B is designed as following shape, not PE(P) terminal.

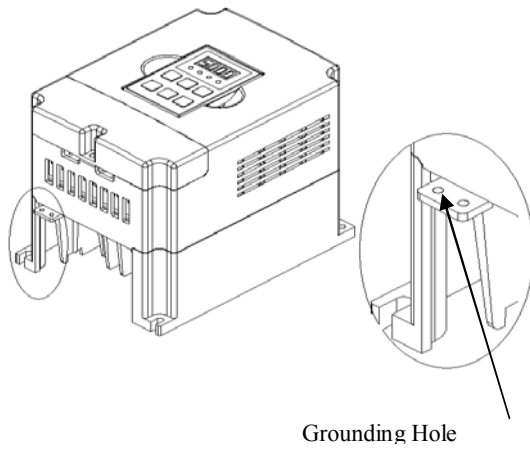

Grounding Hole

Table 3-3 Main Loop Terminals Description

Terminals	Terminal Marking	Terminal Function Description
Power Input Terminal	R, S, T	Three-phase 380V AC input terminal
	L1, L2, L3	For single-phase 220V AC input, connected to L1 and L2; For three-phase 220V AC input, connected to L1, L2 and L3 (Note: no "L3" terminal for single-phase inverter without built-in braking unit).
Output Terminal	U, V, W	Inverter power output terminal, connected to motor.
Terminals	Terminal Marking	Terminal Function Description
Grounding Terminal	PE	Inverter grounding terminal or connected to ground.
Braking Terminal	P, B	External braking resistor (Note: no Terminals P or B for inverter without built-in braking unit).
	P, N	DC bus-line output, externally connected to braking resistor P connected to input terminal "P" of braking unit or terminal "+", N connected to input terminal of braking unit "N" or terminal "-".
	P, P+	Externally connected to reactor

Table 3-4 Wiring Recommended for Input/Output Loop

Inverter Model	Lead Section Area (mm <sup>2</sup> )	Inverter Model	Lead Section Area (mm <sup>2</sup> )
F1500-G0004S2B	1.5	F1500-G0075T3B	4



F1500-G0007S2B	2.5	F1500-G0110T3C	6
F1500-G0015S2B	2.5	F1500-G0150T3C	10
F1500-G0022S2B	4.0	F1500-G0185T3C	16
F1500-G0007T3B	1.5	F1500-G0220T3C	16
F1500-G0015T3B	2.5	F1500-G0300T3C	25
F1500-G0022T3B	2.5	F1500-G0370T3C	25
F1500-G0037T3B	2.5	F1500-G0450T3C	35
F1500-G0040T3B	2.5	F1500-G0550T3C	35
F1500-G0055T3B	4	F1500-G0750T3C	60

 **Warning! : Power terminal shall be tightly secured!**

2) Control Terminal: Terminals of various models are structured as follows:

**A) Control terminal for single-phase 0.4~2.2 KW inverter and three-phase 0.75~7.5kw inverter;**

A+	B-	OUT	24V	CM	OP1	OP2	OP3	OP4	OP5	OP6	OP7	OP8	10V	AN1	GND	FM	IM	AN2	TA	TB	TC
----	----	-----	-----	----	-----	-----	-----	-----	-----	-----	-----	-----	-----	-----	-----	----	----	-----	----	----	----

**B) Control terminal for three-phase 11 ~ 75KW inverter;**

A+	B-	OUT	24V	CM	OP1	OP2	OP3	OP4	OP5	OP6	OP7	OP8	CM	10V	AN1	GND	FM	IM	AN2	TA	TB	TC
----	----	-----	-----	----	-----	-----	-----	-----	-----	-----	-----	-----	----	-----	-----	-----	----	----	-----	----	----	----

 **Warning! : Fastening moment for control terminal: 5kgf.cm.**

Table 3-5 **Control Terminal Functions**

Classification	Terminal	Mfg Function	Function Description	Specification
Output signal of Switching Value	OUT	Operation Indication Signal	Indicating inverter's operation status. OUT: collector open-circuit output with output current not more than 100mA.	Refer to Function Code F416、F417 (P <sub>36</sub> ) for other function settings.
	TA	Fault Indication Signal	Indicating inverter's fault status.	
	TB		TC: common point; TB-TC: normally closed contact , TA-TC: normally open contact. Contact spec:12A 125VAC	
	TC		7A 250VAC 7A 30VDC	

Continued

## Control Terminal Functions

Classification	Terminal	Mfg Function	Function Description	Specification
Analog Output Signal	FM	Voltage Output	Output voltage is proportional to output frequency (or current).	Output voltage range:0~10(5)V Max output current 10mA
	IM	Current Output	Output current is proportional to output frequency (or current).	Output current range: 0(4)~20mA. Terminal's external load impedance not more than 500Ω.
Power Reference	10V	Voltage Source	10V power reference, power reference point: GND terminal.	DC : +10V <100mA
Voltage & Current Analog Signal Input Terminal	AN1	Voltage Input	Both terminals are used for analog signal speed control and PI setting & feedback. Each channel can receive voltage signal input and current signal input. Input analog-signal mode is subject to jumper terminal (refer to P <sub>27</sub> for use of jumper-terminal).	Input voltage:0~10(5)V Input impedance:78KΩ
	AN2	Current Input		Input current: 0(4)~20mA Input impedance:500Ω
Communication terminals	A+	Communication terminal	To communicate with PC or other control system.	Not allow to connect with power supply Input voltage: -7~+12V
	B-	Communication terminal	To communicate with PC or other control system.	Not allow to connect with power supply Input voltage: -7~+12V
Reference gnd	GND	Reference gnd	Reference gnd for 10V voltage source	Connected with "CM", "PE" or "N" terminals is unallowed
Power Source	24V	Control Power Supply	Accessory power-supply for input terminal. Power-supply common port is CM terminal.	DC : +24V <200mA
Common Port	CM	Common Port	Common port for OP1~OP8 terminal and 24V power-supply.	Connected with "GND", "PE" or "N" terminal is unallowed.
External Control Terminal Input	OP1	Jogging Corotation	connection between this terminal and CM can affect jogging forward running.	Refer to F408~F415 (P <sub>34</sub> ) for other function settings.
	OP2	Multi-stage Speed Control Terminal	"Multi-stage Speed" transfer terminal.	
	OP3			
	OP4			
	OP5	External Emergency Stop	Input emergency stop signal, and inverter will display "ESP" fault signal.	
	OP6	"FWD" Terminal	Refer to Table 5-2 (P <sub>29</sub> ) Terminal Control Mode for inverter terminals running control terminal.	
	OP7	"REV" Terminal		
OP8	Reset	Connection between this terminal and CM can reset inverter.		

## IV. OPERATION & DISPLAY

### 4.1 Keypad Control Unit

#### 4.1.1 Operation Panel Instruction

There are two types of keypad control units with F1500-G series inverter (with or without potentiometer), with two kinds of dimensions for each keypad control unit. Refer to Fig 4-1 notes.

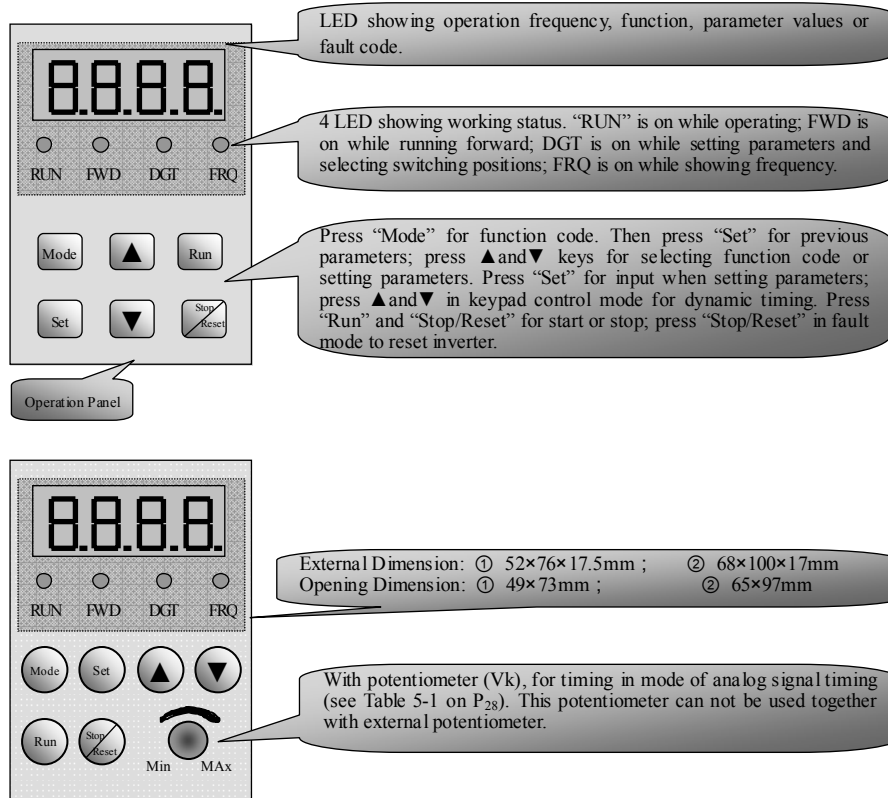







Fig 4-1 Two Types of Keypad Control Units

## 4.1.2 Keypad Instruction

Table 4-1

Key Instruction

Keys	Key Name	Description
	“Mode” Key	Entering the display mode of “function code editing”; To switch for different displays in operation status to reflect various parameters (P <sub>24</sub> ); Press this key in status of amending parameters. Return to display mode of “function code editing” without saving the data amended.
	“Set” Key	Enter “function-code parameters amending” mode from “function code editing” mode. This key is used for saving data and returning to “function-code editing” mode in the mode of “function-code parameters amending”.
	“Up” Key	This key is used for data increasing by degrees in the display mode of “function-code editing”, “function-code parameters amending” and frequency display. Step-length of frequency-setting is selected by function code F230 (P <sub>31</sub> ), between 0.01 ~ 1.00Hz.
	“Down” Key	This key is used for data decreasing by degrees in the display mode of “function-code editing”, “function-code parameters amending” and frequency display. Step-length of frequency-setting is selected by function code F230 between 0.01 ~ 1.00Hz.
	“Run” Key	To start inverter for operation in keypad control mode (F200 = 0).
	“Stop/Reset” Key	This key is for several purpose: 1): Reset in protection status; 2): Select fuction code among the zone of function codes in display mode of “function-code editing”; 3): Select data-bit while setting parameters; 4): As F201=0, this key can stop inverter in mode of keypad control; As F201=1, this key can stop inverter in mode of keypad control, and has the function of “external emergency stop” in the mode of terminal control and computer remote control; As F201 = 2, this key can stop inverter in mode of keypad and terminal 3-line control, direction pulse controlling start/stop, and computer remote control. Please refer to P <sub>26</sub> about the actual “stop” function.

### 4.2 Function Parameters Setting

Users can adopt various application modes for changing function-code parameters. Please input user's password properly in F100 if parameters should be set after it is reconnected to power (user's password is 8 for manufacturer's setting or after restoring manufacture's password). Upon correct input of password, user may change his password again.

Table 4-2 Parameter Setting Steps

Step	Key	Operation	Display
1	Mode	Press "Mode" to display function code.	F100
2	Stop/Reset	Press "stop/reset". If "DGT" indicator is off, press "▲/▼" for selection of function-code zone; if "DGT" indicator is on, press "▲/▼" to select the function code that need be amended in the selected function-code zone.	F100
3	▲ or ▼	Press "▲/▼" keys for selection of the desired function code.	F114
4	Set	Press "set" key to call the data set in function-code.	20.0
5	Stop/Rreset	Press "stop/reset" keys to select the data bit to be edited. The selected data-bit will flash to indicate that this bit is editable.	0.0
6	▲ or ▼	Press "▲/▼" for amending the selected data-bit.	0.0
7	Set or Mode	Press "set" to save data, and return to the present function-code. Press "mode", then the amended data is invalid, displaying the present function code.	F114

Table 4-2 Process is illustrated as below:

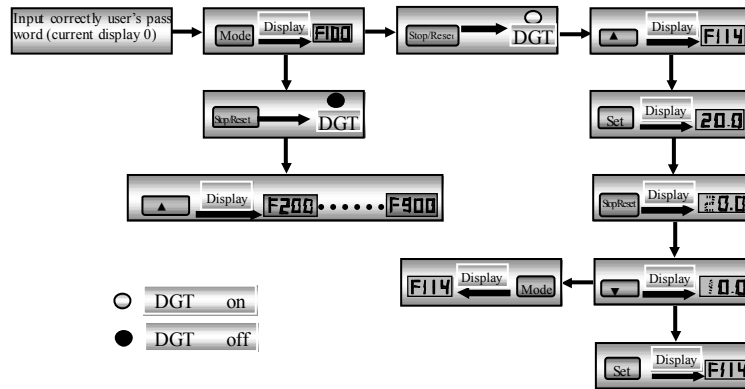

Fig 4-2 Parameter Setting Steps

### 4.3 Function-Codes Grouping

More than 200 function-codes are available, divided into 9 zones, as shown in Fig 4-3.

Fig 4-3 **Function-Codes Grouping**

Items	Function-codes	zones
Basic Parameters	F100 ~ F160	1
Operation Control Parameters	F200 ~ F260	2
Multi-stage Speed Parameters	F300 ~ F360	3
Programmable Input/Output Terminal Parameters	F400 ~ F460	4
V/F Control Parameters	F500 ~ F560	5
PI Setting Parameters	F600 ~ F660	6
Timing & Definable Protection Parameters	F700 ~ F760	7
Analog signal Parameters	F800 ~ F860	8
Communication Parameters	F900 ~ F960	9

### 4.4 Panel Displays

Fig 4-4 **Panel Display Items & Descriptions**

Items	Descriptions
<b>- HF—</b>	It stands for resetting process: inverter will flash the preset frequency after resetting.
<b>50.00</b>	Flashing on inverter after connected to power. It is the set frequency for inverter's running. "▲/▼" keys can set digital setting.
<b>10.00</b>	Steady display on control panel. It means the inverter's running frequency or parameter settings.
<b>F112</b>	Function-codes (parameter codes).
<b>A 2.5</b>	It means output current 2.5A.
<b>U100</b>	It means output voltage 100V.
<b>L 10.0</b>	It means linear velocity of 10meters/second.
<b>100</b>	It implies either rotate speed (100rpm), or count values (100pcs), to be differentiated as per the actual case by users.
<b>1.345</b>	It means rotate speed (13,450 rpm)
<b>OC1, OC2, OC3, OE1, OE2, OE3, OL1, OL2, LU, PEr, OH, AdEr, Cb, ESP, ErP, Err</b>	Malfunction Info (refer to Appendix 1 on P <sub>52</sub> ).

## V. Function & Parameters Instruction

### 5.1 Basic Parameters

F100	User's Code	Setting Range: 0 ~ 9999	Mfr Value: 8
------	-------------	-------------------------	--------------

·Enter correct user's password after power connection if you intend to change parameters. Otherwise, parameter setting will not be possible.

·Use may change "user's password", same as changing other parameters.

F102	Inverter's Rated Current (A)		Mfr Value: subject to inverter model
F103	Inverter Power (KW)	Setting Range: 0.40 ~ 75.0	Mfr Value: power value of this inverter
F105	Software Edition No.		
F106	Inverter's Input Voltage Type	Setting Range: 1: single phase 3: three phase	Mfr Value: subject to inverter model
F107	Inverter's Rated Input Voltage(V)	Setting Range: 220 or 380	Mfr Value: subject to inverter model

·Preset by manufacturer, used for recording product' power, corresponding input voltage, rated values and software edition, as info for user.

F111	Max Frequency (Hz)	Setting Range: F112 ~ 400.0	Mfr Value: 60.00
------	--------------------	-----------------------------	------------------

·It shows the max frequency for inverter's operation.

F112	Min Frequency (Hz)	Setting Range: 0.00 ~ MIN(50.00, F111)	Mfr Value: 0.00
------	--------------------	--	-----------------

·It shows the min frequency for inverter's operation.

·MIN(50.00, F111): it means the lower one of the two values between 50.00 and F111.

e.g.: if F111 = 40.00, F112's setting range will be 0.00 ~ 40.00; if F111 = 60.00, F112's setting range will be 0.00 ~ 50.00.

F113	Digital Setting Frequency (Hz)	Setting Range: F112 ~ F111	Mfr Value: 50.00
------	--------------------------------	----------------------------	------------------

·When inverter frequency-setting mode is "Digital Frequency Setting" (i.e., F204=0 or 1), frequency can be preset with this function-code. Inverter will automatically run to this frequency after started.

·Frequency can be set by keypad "▲/▼" or "UP" and "DOWN" terminal.

F114, F116	1 <sup>st</sup> and 2 <sup>nd</sup> Acceleration Time (S)	Setting Range: 0.1 ~ 3000	Mfr Value: 20.0
F115, F117	1 <sup>st</sup> and 2 <sup>nd</sup> Deceleration Time (S)		

· "Acceleration Time" refers to the time for inverter to accelerate to the max frequency (F111) from 0Hz;

"Deceleration Time" refers to the time for inverter to decelerate to 0Hz from the max frequency (F111).

·when function of programmable input terminal (OP1 ~ OP8) is set to “16 (acceleration/ deceleration time switchover )”, this terminal can be used for switchover of first and second acceleration/ deceleration time.  
 When a low power-level is input into this terminal , inverter will select second acceleration/ deceleration time. Otherwise, first acceleration/ deceleration time shall be default.

F118	Turnover Frequency ( Hz )	Setting Range: 50.00 ~ 400.0	Mfr Value: 50.00
------	---------------------------	------------------------------	------------------

·Motor’s rated frequency.  
 ·When running frequency is lower than this value, inverter will output constant-torque. When exceeding this value, inverter will output constant power. Normally 50Hz will be selected for turnover frequency.

F119	Latent Frequency ( Hz )	Setting Range: F112 ~ F111	Mfr Value: 5.00
------	-------------------------	----------------------------	-----------------

·When output frequency exceeds this value; it will be programmed as output status reverse for OUT terminal (or relay terminal) with “Over Latent Frequency” function; in case below this frequency, the terminal will be restored.

F120	Forward/reverse Switchover Dead-Time ( S )	Setting Range: 0.0 ~ 3000	Mfr Value: 2.0
------	--	---------------------------	----------------

· This parameter refers to the transition time required during output of 0Hz when inverter change from forward running to reverse running( as shown in Fig 5-1). To set this function may ease the current strike in the course of direction switchover.

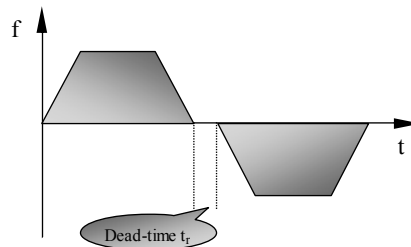

Fig 5-1 Forward/reverse Switchover Time

· Within “forward/reverse switchover dead-time”, inverter will stop immediately upon receiving “stop” signal.

F121	Stopping Mode	Setting Range: 0: stop by deceleration time 1: free-stop	Mfr Value: 0
------	---------------	--	--------------

· “Stop by Deceleration Time” means that motor controlled by inverter will slow down and stop at 0Hz by the set deceleration time.  
 · “Free Stop” means that after inverter cuts off output upon receiving “stop” instruction, motor will run freely and stop by inertia. “Free Stop” mode will be selected by function-code F700 (P<sub>42</sub>) (0: free stop



immediately 1: delayed free stop) and F701 (Delay time of Free-Stop and Programmable Output Terminal's Action ).

F122	Reverse Running Forbidden	Setting Range: 0:null 1: valid	Mfr Value: 0
------	---------------------------	--------------------------------	--------------

·This function may avoid damage on equipment due to mis-operation causing motor-reverse running.

F124	Jogging Frequency (Hz)	Setting Range: F112 ~ F111	Mfr Value: 5.00
F125	Jogging Acceleration Time(S)	Setting Range: 0.1 ~ 3000	Mfr Value: 20.0
F126	Jogging Deceleration Time (S)		

·Jogging function only applies to terminal control mode (F200 = 1).

·Jogging operation can be realized by connected CM with the programmable input terminal (OP1 ~ OP8) defined as jogging function.

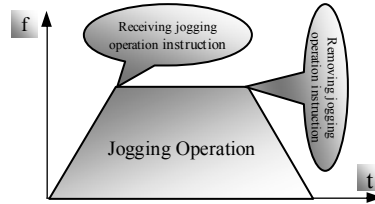

Fig 5-2 Jogging Operation

F127, F129	Skip Frequency A,B (Hz)	Setting Range: 0.00 ~ F111	Mfr Values: 0.00
F128, F130	Skip Width A,B (Hz)	Setting Range: 0.00 ~ 5.00	Mfr Values: 0.00

·Systematic vibration may occur when the motor is running at a certain frequency. This parameter is set to skip this frequency.

·The inverter will skip the point automatically when output frequency is equal to the set value of this parameter.

·“Skip Width” is the span from the upper to the lower limit around Skip Frequency.

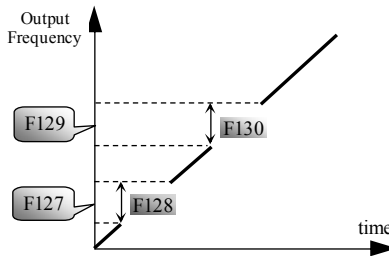

Fig 5-3 Skip Frequency

·As shown in Fig 5-3: Skip Frequency=20Hz, Skip Width=5.00, inverter will skip automatically when output is between 17.5 ~ 22.5Hz.

F131	Displays	Setting Range: 1 ~ 127 1: Frequency 2: Rotate Speed 4:Count Values 8: Output Current 16: Function-Code Editing 32:Output Voltage 64:Linear Velocity 127: Display All	Mfr Values: 127
------	----------	---	-----------------

· Selection of any value from 1, 2, 4, 8, 16, 32 and 64 shows that only one specific display item is selected.

Should multiple display items be intended, add the values of the corresponding display items and take the total values as the set value of F131, e.g., just set F131 to be 25 (1+8+16) if you want to call “frequency”, “output current” and “function-code editing”. The other display items will not appear.

Display	Indication	Unit
Frequency	50.00	Hz
Rotate Speed	300	rpm
	1.345	10,000 rpm
Count Value	99	
Output Current	A 3.5	Ampere
Function-Code Editing	F112	
Output Voltage	U100	Volt
Linear Velocity	L7.85	meter/second

· As F131 = 127, all display items are visible, of which, “function-code editing” will be visible whether or not it is selected.

· Should you intend to check any display item, just press “mode” for switchover.

· Refer to the right table for each specific physical unit and its indication:

F132	Number of motor pole pairs	Setting Range: 1 ~ 6	Mfr Value: 2
F133	Driven system’s drive ratio	Setting Range: 0.1 ~ 100.0	Mfr Value: 1.0
F134	Transmission-wheel radius (m)	Setting Range: 0.001 ~ 1.000	Mfr Value: 0.001

· Calculation of retoting speed and linear velocity:

If inverter’s max frequency F111 = 50.00Hz, number of motor pole pairs F132 = 2 , drive-ratio F133 = 1.0 , Transmission-wheel radius F134 = 0.05m, then

Transmission-wheel perimeter:  $2\pi r = 2 \times 3.14 \times 0.05 = 0.314$  (meter)

Transmission shaft rotate speed: [  $60 \times \text{operation frequency} / (\text{number of pole pairs} \times \text{drive ratio}) ] \times (1 - 0.03) = 60 \times 50 / (2 \times 1.00) \times (1 - 0.03) = 1455 \text{rpm}$

(0.03: slip ratio)

final linear velocity: rotate speed  $\times$  perimeter =  $1455 \times 0.314 = 456.87$  (meter/minute) = 7.61 (meter/second)

F139	whether to start automatically after reconnection to power or malfunction	Setting Range: 0: null 1: valid	Mfr Value: 0
------	---	---------------------------------	--------------

· This function means that inverter is reconnected after power disconnection or whether it can be started automatically after malfunction protection. If inverter is selected “null”, it shall start to operate only after receiving “run” signal.

- After auto start by inverter, F705 and F706(P<sub>42</sub>) shall set the times and intervals for auto-start.
- This function only applies to control modes of keypad control (F200 = 0) , 3-line control (F200 = 1, F208 = 2 or 3) and direction-pulse controlled start/stop (F200 = 1 and F208 = 4).

F160 Reverting to manufacturer values	Setting Range:	Mfr Value: 0
	0:Not reverting to manufacturer values; 1 : Reverting to manufacturer values	

·Set F160 to 1 when there is disorder with inverter’s parameters and manufacturer values need to be restored.

- After “Reverting to manufacturer values” is done, F160 values will be automatically changed to 0.

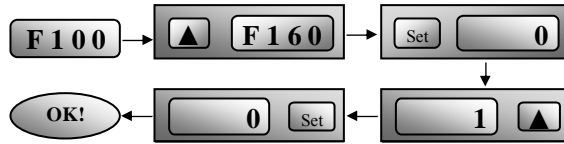



Fig 5-4 Reverting to manufacturer values

- “Reverting to manufacturer values” will not work for the function-codes marked “○” in the “Note” column in the Appendix 2 Function-Code Zoom Table.

### 5.2 Operation Control Parameters

F200 Operation Control	Setting Range:	Mfr Value: 0
	0: Keypad Control/485Communication Control 1: Terminal Control 2: Computer Remote Control	

- “Keypad Control/485Communication Control” means that inverter’s running is controlled by keypad or control box connected by 485-communication interface. Motor’s rotate-direction is set by F207 ( P<sub>28</sub> ) .
- “ Terminal Control” shall control inverter’s operation through programmable input terminal named with “FWD”, “REV” and “X” functions (OP1 ~ OP8). Four control modes are available in mode of terminal control. Refer to function-code F208 ( P<sub>28</sub> ) .
- “Computer Remote Control” means that computer will control inverter’s operation through 485-communication interface.

F201  Key Functions	Setting Range:	Mfr Value: 0
	0: valid only in mode of keypad control 1: valid in any modes 2: valid at time of keypad, terminal 3-line control, controlling start/stop by direction pulse and computer remote control	

- As F201 = 0, and in mode of keypad control, press this key during running, inverter will stop by deceleration

time.

·As F201 = 1, and in mode of keypad control, press this key during running, inverter will stop by deceleration time; in mode of terminal control or computer remote control, press this key during running, inverter will stop. Meanwhile, keypad control unit will display error signal “ESP”.

·As F201 = 2, this key will work in modes of keypad, terminal 3-line control, start/stop controlld by direction-pulse, code-timing and computer remote control. Press this key during running, inverter will stop by deceleration time.

·As inverter is having stalling operation, press this key during running, inverter will stop. Meanwhile, keypad control unit will display error signal “ESP”.

<p>F204 Basic Speed ControlModes</p>	<p>Setting Range:                  0: setting digital frequency, setting keypad and terminal UP and DOWN, not saving result when power off.                  1: setting digital frequency, setting keypad and terminal UP and DOWN, saving result when power off.                  2: Multi-Speed control.                  3: Analog Channel 1 ( AN1 ) Speed control.                  4: Analog Channel 2 ( AN2 ) Speed control.                  5: Analog Channel Compound Speed-Control 1: <math>k1 * AN1 + k2 * AN2</math> ( of which, “AN1” and “AN2” implies the analog signal input by Analog Channel AN1 and AN2).                  6: Analog Channel Compound Speed-Control 2: <math>k1 * AN1 - k2 * AN2</math> ( Same as above with “AN1” and “AN2” ) .                  7: Speed control set by pulse frequency.                  8: Code Speed Control means inverter is run by various switching status combination of terminals OP1 ~ OP8.                  9: Analog Channel Compound Speed-Control 3: <math>k1 * AN1 + k2 * ( AN2 - 5V )</math> .                  10: Keypad potentiometer speed-control selection</p>	<p>Mfr Value:0</p>
--	---	------------------------

·Multi-stage speed control includes multi-stage speed running, automatic circulating running and 8-stage speed running, to be selected by function-code F210 (P<sub>29</sub>). Running frequency of stage speed can be adjusted with keypad “▲/▼” keys or “UP” and “DOWN” terminals The result of frequency adjusting is unsaved

when power off. Refer to **5.3 Multi-stage Speed Parameters** (P<sub>31</sub>) for relevant function parameters setting.

- In case of speed control with analog signal, please set F800, F801, F807 and F808 (P<sub>41</sub>) according to the input of actual analog signal and frequency setting requirements. Meanwhile, select the input analog type through jumper terminal.
- Input analog will set inverter's running frequency or PI adjusting.
- Speed-control set by pulse-frequency means that inverter will be controlled through pulse-frequency input by OP1 terminal (F408=23) from peripheral equipment.
- Refer to F809 and F810 (P<sub>45</sub>) for relevant function parameters.
- In case of code speed-control, frequency will be set by input terminal programmed with code speed control function (this terminal function is defined as 18):

$$\text{Code Speed-Control Frequency} = \text{binary-digit of terminal-input} * \text{max frequency}/255$$

While using code speed control, input terminal function of input terminal OP1 ~ OP8 can be redefined.



- Refer to **6.2 Speed Control Mode** for various speed control modes.



**Use of Jumper Terminal**

Fig 5-1 **Jumper Terminal Status Vs Corresponding Function Realised**

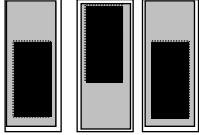
For 3-phase 380V 0.75~7.5kw inverter, there are totally four jumper terminals.

The status of jumper terminals and the corresponding function is listed as follows.

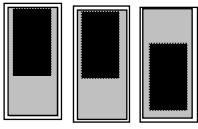
Function Realised	Jumper-Terminal Status	Function Realised	Jumper-Terminal Status
Input voltage analog through analog channel 1(AN1)	 <p>1 2 3</p>	Input voltage analog through analog channel 2(AN2)	 <p>4</p>

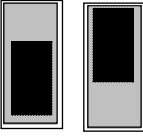
Input current analog through analog channel 1(AN1)	 <p>1    2    3</p>	Input current analog through analog channel 2(AN2)	 <p>4</p>
Input voltage analog of keypad control unit (only for keypad control unit with potentiometer)	 <p>2    3</p> <p>Note: user still should set F204=3.</p>		

For inverters of 1-phase 220V 0.4~2.2kw and 3-phase 380V 11~75kw, there are totally two jumper terminals. The status of jumper terminals and the corresponding function is listed as follows.

1. The input singals of AN1 is controlled by No. 1 Path of the jumper terminals. When the No. 1 Path is on the position of "1", the voltage signals of 0~10(5)V is input. When the No. 1 Path is on the position of "ON", then the current signals of 0(4)~20mA is input.
2. The input singals of AN2 is controlled by No. 2 Path of the jumper terminals. When the No. 2 Path is on the position of "2", the voltage signals of 0~10(5)V is input. When the No. 2 Path is on the position of "ON", then the current signals of 0(4)~20mA is input.
3. If voltage analog of keypad control unit (only for keypad control unit with potentiometer) is input, F204 should be set as "10".

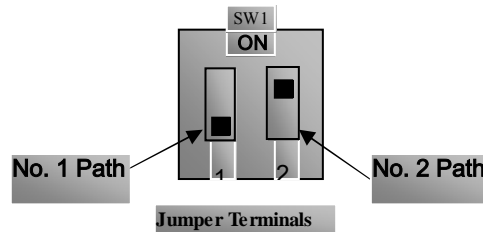

F207    Keypad Direction Set	Setting Range: 0:forward; 1:reverse	Mfr Value: 0
------------------------------	-------------------------------------	--------------

· In mode of keypad control (F200 = 0), set motor's running direction.

F208 Terminal Control Mode	Setting Range: 0: two-line type 1 1: two-line type 2 2: three-line type 1 3: three-line type 2 4: start/stop controlled by direction pulse	Mfr Value: 0
----------------------------	---	--------------

· Five modes are available for terminal operation control. As shown in Fig 5-2, “ $\overline{0}$ ” stands for switch-on, “ $\overline{0}$ ” for normally closed contact, “ $\frac{1}{0}$ ” for normally open contact. “FWD”, “REV” and “X” are three terminals designated in programming OP1 ~ OP8.

Fig 5-2 Terminal Control Mode

F208	Terminal Function Realised and Control-Loop Wiring
0: two-line type 1 forward/stop reverse/stop	<p>“FWD” terminal—“open”: stop, “close”: forward running                      “REV” terminal—“open”: stop, “close”: reverse running                      “CM” terminal—common end</p> <p style="text-align: right;"><b>F1500-G</b></p>
1: two-line type 2 reverse/forward running/stop	<p>“FWD” terminal—“open”: stop, “close”: running                      “REV” terminal—“open”: forward, “close”: reverse                      “CM” terminal—common end</p> <p style="text-align: right;"><b>F1500-G</b></p>
2: three-line type 1 forward running/stop reverse running/stop	<p>“X” terminal—(“open”: stop)                      “FWD” terminal—(forward running signal, “close”: forward running)                      “REV” terminal—(reverse running signal, “close”: reverse running)                      “CM” terminal—common end</p> <p style="text-align: right;"><b>F1500-G</b></p>
3: three-line type 2 forward running/stop reverse running/stop	<p>“FWD” terminal—(“close”: running)                      “X” terminal—(“open”: stop)                      “REV” terminal—(forward /reverse running selection)                      “open”: forward running                      “close”: reverse running                      “CM” terminal—common end</p> <p style="text-align: right;"><b>F1500-G</b></p>
4: start/stop controlled by direction impulse. forward running/stop reverse running/stop	<p>“FWD” terminal—(impulse start/stop signal: forward/stop)                      “REV” terminal—(impulse start/stop signal: reverse/stop)                      “CM” terminal—common end</p> <p style="text-align: right;"><b>F1500-G</b></p>

F209 Stage-Speed Changing Control	Setting Range: 0: adjusting stage-speed forbidden 1: adjusting stage-speed allowed	Mfr Value: 0
F210 Stage-Speed Types	Setting Range: 0: multi-stage speed running 1: Auto circulating running 2: 8-stage speed running	Mfr Value: 0
F211 Auto Circulating Running Speed Selection	Setting Range: 2 ~ 7	Mfr Value: 7
F212 Auto Circulating Running Times Selection	Setting Range: 0 ~ 9999	Mfr Value: 0
F213 Free Running Selection after Auto Circulating Running	Setting Range: 0: stop 1: keep running at last stage speed	Mfr Value: 0

· Stage-Speed change control means whether keypad “▲/▼”keys or “UP” and “DOWN” terminals will be used during multistage speed running to adjust the present running speed. F230 (P31) sets step-length for each adjusting. This setting will not change function-code parameters, and will not be saved in memory when power disconnected. Parameters set by function-code will therefore be called for multistage speed frequency again when power reconnected.

- “Once” means auto circulating running at all fixed stage speeds for one time.
- If F212 = 0, inverter will keep circulating running until it is stopped by “stop signal”.
- If F212>0, inverter will finish auto circulating running in the mode set by F213 after inverter makes circulating running for the fixed times ( to be set by F212): if F213=0, then it will stop; if F213=1, then running will be kept at the last speed.

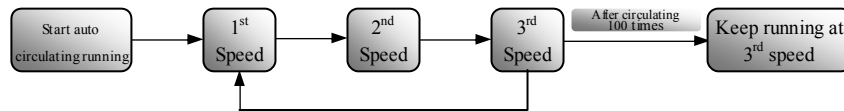

Fig 5-5 Auto Circulating Running

e.g.: F211=3, F212=100, F213=1, select auto circulating running at 3 speeds for 100 times. After auto circulating running, keep running at 3<sup>rd</sup> speed.

F214	k1	Setting Range: 0.0 ~ 10.0	Mfr Value: 1.0
F215	k2	Setting Range: 0.0 ~ 10.0	Mfr Value: 1.0

·k1 and k2 are proportion parameters in case of (F204=5, 6, 9). When compound speed control, the actual



value of input analog will be the product of set value for peripheral equipment and proportion parameters.  
 e.g. when  $k_1 = 0.5$ ,  $k_2 = 2.0$ , scope for analog which is input into inverter through AN1 channel is 0.0 ~ 5.0V; scope for analog which is input into inverter through AN2 channel is 0.0 ~ 20.0V.

F221	Count Frequency Divisions	Setting Range: 1 ~ 1000	Mfr Value: 1
F222	Set Count Times	Setting Range: F224 ~ 9999	Mfr Value: 1
F224	Designated Count Times	Setting Range: 1 ~ F222	Mfr Value: 1

Count frequency divisions refer to the ratio of actual pulse input and inverter's count times, i.e.,

$$\text{Inverter's Count Times} = \frac{\text{Actual Pulse Input}}{\text{Count Frequency Division}}$$

e.g. when  $F221 = 3$ , inverter will count once for every 3 inputs of external impulse.

Set count times refer to a count width pulse output by the output terminal (OUT terminal or relay) programmed with "reaching the set count times" function when a certain number of pulses are input from OP1. Count will restart after the count value reaches "fixed times".

As shown in Fig 5-6: if  $F221=1$ ,  $F222 = 8$ ,  $F417 = 7$ , OUT will output an instruction signal when OP1 inputs the 8<sup>th</sup> pulse.

Designated count times refer to an pulse output by the output terminal (OUT or RELAY terminal) programmed with "reaching the set count times" function when a certain number of pulses are input from OP1, until count value reaches the "set times".

As shown in Fig 5-6: if  $F221=1$ ,  $F224 = 5$ ,  $F222 = 8$ ,  $F416 = 8$ , relay will output an instruction signal when OP1 inputs the 5<sup>th</sup> pulse, relay will output an instruction signal until reaching "fixed count times 8".

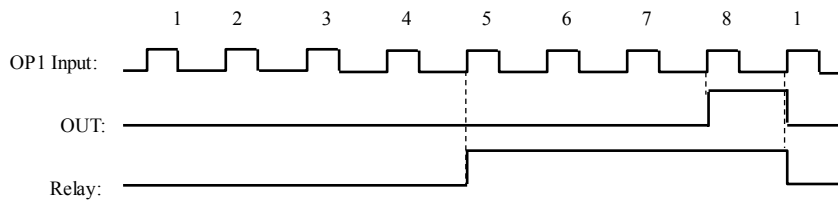

Fig 5-6 Set Count times & Fixed Count Times

F230	Frequency Setting Step length (Hz)	Setting Range: 0.01 ~ 1.00	Mfr Value: 0.01
------	------------------------------------	----------------------------	-----------------

This parameter means the changing frequency value when adjusting "▲/▼" keys once or press "UP" and "DOWN" terminal once.

### 5.3 Multistage Speed Parameters

F300, F306, F312, F318, F324, F330, F336 Stage-Speed Running Direction	Setting Range: 0: Forward; 1: Reverse	Mfr Value: F300 = 0 F306 = 1 F312 = 0 F318 = 1 F324 = 0 F330 = 0 F336 = 0
---	--	---

·Running direction will be provided for each speed.

·When keypad control/485 communication control (F200 = 0) or computer remote control (F200 = 2), stage-speed running direction will be set by the above function-code; when controlled by terminal (F200 = 1), stage-speed running direction will be controlled by the input terminal defined with “FWD”, “REV” and “X” functions (See P<sub>29</sub> Table 5-2).

F301, F307, F313, F319, F325, F331 and F337 Stage-Speed Acceleration time (S) F304, F310, F316, F322, F328, F334 and F340 Stage-Speed Deceleration time(S)	Setting Range: 0.1 ~ 3000	Mfr Value: 20.0
---	---------------------------	-----------------

· Acceleration time and deceleration time will be provided for each speed.

F302, F308, F314, F320, F326, F332 and F338 Stage-Speed Running Frequency (Hz)	Setting Range: F112 ~ F111	Mfr Value: F302 = 5.00 F308 = 10.00 F314 = 15.00 F320 = 20.00 F326 = 25.00 F332 = 30.00 F338 = 35.00
---	----------------------------	--

·Running frequency for each speed will be provided.

·In case of multistage speed control, speed control is allowed for running frequency of stage-speed by using

“▲ /▼ ” keys or “UP” and “DOWN” terminals.

F303, F309, F315, F321, F327, F333 and F339 Stage-Speed Running Time(S)	Setting Range: 0.1 ~ 3000	Mfr Value: 20.0
--	---------------------------	-----------------

·Running time will be provided for each speed.

· When auto circulating running (F210 = 1), stage-speed running time will be set by the above function-codes: In case of multistage running (F210 = 0) or running at 8<sup>th</sup> speed (F210 = 2), it will be running at stage-speed and peripheral equipment control will be stopped. Therefore It is not restricted by stage-speed running time.

F305, F311, F317, F323, F329, F335, F341 Stage-Speed Stop/Waiting Time(S)	Setting Range: 0.0 ~ 3000	Mfr Value: 0.0
---	---------------------------	----------------

·Stop/waiting time will be provided for each speed.

·When auto circulating running (F210 = 1), inverter will use stage-speed stop/waiting time; in case of multistage running (F210 = 0) or running at 8<sup>th</sup> speed (F210 = 2), it will be running at stage-speed and peripheral equipment control will be stopped. It is therefore not restricted by stage-speed stop/waiting time.

F342 Selection of Compound Speed Control for Stage-Speeds	Setting Range: 0: not allowed 1: allowed	Mfr Value: 0
F343 Selection of Compound Speed Control Mode for Stage-Speeds	Setting Range: 0: multi-stage running frequency + values set for F344 1: Multi-stage running frequency + AN2 channel analog values	Mfr Value: 0
F344 Digital Frequency Setting for Stage-Speed Compound Speed Control ( Hz )	Setting Range: 0.00 ~ 20.00	Mfr Value: 0.00

·Compound speed control for stage-speeds can be controlled together by multi-stage speed control, digital speed control and analog speed control. This speed control mode only works for multi-stage and 8-stage running, not for automatic circulating running, i.e., such condition must be met as F210 = 0 or 2 when selecting compound speed control.

·F343 = 0, select the control mode both by multistage speed control and digital speed control. The running frequency at each speed will then be the sum adding multistage speed frequency and set values of digital frequency. Set values of digital frequency will be set by F344.

e.g. the values set for current running frequency for each stage speed: F302 = 5.00, F308 = 10.00, F314 = 15.00, F320 = 20.00, F326 = 25.00, F332 = 30.00, F338 = 35.00. To set F344 = 10.00, running frequency for each stage speed in case of compound speed control: F302 = 15.00 , F308 = 20.00 , F314 = 25.00 , F320 = 30.00 , F326 = 35.00 , F332 = 40.00 , F338 = 45.00.

·F343 = 1, select the control mode both by multistage speed control and analog speed control. The running frequency at each speed will then be the sum adding multistage speed set frequency and AN2 channel analog values. Analog value set for AN2 is 0 ~ 10V (to be provided by peripheral equipment through AN2 channel), corresponding frequency 0 ~ 10Hz.

e.g., the values set for running frequency at each speed: F302 = 5.00, F308 = 10.00, F314 = 15.00, F320 =

20.00, F326 = 25.00, F332 = 30.00 and F338 = 35.00. If the values set for “AN2” channel analog is 5.0V, running frequency at each speed at time of compound speed control: F302 = 10.00 , F308 = 15.00 , F314 = 20.00 , F320 = 25.00 , F326 = 30.00 , F332 = 35.00 , F338 = 40.00.

## 5.4 Programmable Input & Output Terminal Parameters

### 5.4.1 Programmable Input Terminal

F408 ~ F415 Terminal Function Definition	Setting Range: 0 ~ 23	Mfr Value: F408 = 9; F409 = 1; F410 = 2; F411 = 3; F412 = 7; F413 = 13; F414 = 14; F415 = 4
--	-----------------------	--

· Terminal function OP1 ~ OP8 will be defined separately. 22 functions can be available for each terminal.

Table 5-3 Programmable Input Terminal Function

F408 ~ F415	Description	Remarks
0	No Function	
1	Multi-Speed Terminal1	Used in defining multi-speed function, refer to 6.2 Speed Control Mode (P <sub>47</sub> ) for multi-speed control.
2	Multi-Speed Terminal 2	
3	Multi-Speed Terminal 3	
4	Reset	When malfunction protection occurs, this terminal is connected with CM, which will reset converter.
5	Free-stop	During it's working ,this terminal is connected with CM, which will bring converter to free stop.
6	Reserved	
7	External Emergency Stop	The inverter will stop output immediately if it receives “external emergency stop”signal during running. “ESP” malfunction signal will be displayed in the meanwhile. Resetting will be possible after signal of “external emergency stop” is released.

8	Acceleration/Deceleration Prohibited	During acceleration/deceleration, this terminal works (i.e. this terminal is connected CM). Inverter stops acceleration/ deceleration , and keeps the present running frequency, this terminal does not work ( i.e.this terminal breaks up with CM ) , acceleration/deceleration process will continue.
9	Jogging Forward Running JOGF	Connecting terminal with CM could make jogging forward running.
10	Jogging reverse running JOGR	Short circuit of this terminal with CM could make jogging reverse running.
<b>Table 5-3 (continued) Programmable Input Terminal Function</b>		
F408 ~ F415	Description	Remarks
11	Frequency Increasing by Degrees UP	This terminal is equal to the “▲” key on the operation panel.
12	Frequency Decreasing by Degrees DOWN	This terminal is equal to the “▼” key on the operation panel.
13	“FWD”Terminal	Control terminal for inverter terminal running. Refer to Table 5-2 (P <sub>29</sub> ) for terminal control mode.
14	“REV” Terminal	
15	Three-line Type, Input Terminal of “X”	One terminal of the three-line control mode, used to stop inverter (P <sub>29</sub> ).
16	Switchover of Acceleration/Deceleration Time	Used in switchover of the first and the second acceleration / deceleration times. When this terminal is working (i.e.it is connected with CM), the second acceleration/deceleration time is carried out. When this terminal is not working (i.e. it is disconnected with CM), then the first acceleration/deceleration time is used.
17	Peripheral Equipment Malfunction	The inverter will stop output immediately and display “ErP”if it receives the terminal input signal of “peripheral equipment malfunction” during operation. Resetting will not be done until the signal of “peripheral equipment malfunction” is released.
18	“Coding Speed Control” Input Terminal	When this function is selected , OP1 ~ OP8 will be binary digital input terminal. OP1 terminal corresponds to low bit of the binary digit while OP8 corresponds to high bit of the binary digit, and by analogy. Set to 1 when the terminals of the corresponding position is working; otherwise reset to 0.
19	Close Loop Switched to Open Loop	Switch the speed control mode PI to that of F204: When the function terminal is open circuit with CM, it will be controlled by the close loop. When it is connected with CM, by open

		loop.
20	Compound Channel Speed Control Switched to Single Channel Speed Control	Realize the switchover between compound speed control and single-channel analog speed control (default: AN1 channel).
21	Terminal Counting	Input of count pulse of the built-in counter.
22	Count Value Reset to Zero	Reset the terminal count value to zero.
23	Pulse Frequency Input Terminal (Only valid for OP1)	When F408 = 23 , set the speed with the external input pulse. Max frequency of the pulse input: 9999Hz.



**Warning!:** 1. The count pulse frequency of the input terminal must not exceed 300Hz. Otherwise the counter error will appear.

2. Terminal functions are not allowed for redefinition except for coding speed control.

**5.4.2 Programmable Output Terminal**

F416	Relay Output	Setting Range : 0 ~ 13	Mfr Value:1
F417	OUT Terminal Output		Mfr Value:4

·Programmable output terminal includes collector open-circuit output terminal OUT and relay output terminals TA, TB and TC.

·The output terminal “action” in the following table refers to the relay sucking: TA closes TC, TB disconnects TC disconnection, OUT terminal is on status with low resistance.

Table 5-4 **Programmable Output Terminal Function**

F416, F417	Description	Remarks
0	No Function	
1	Inverter Malfunction Protection	This terminal will be “action” when inverter has malfunction protection except for undervoltage protection.
2	Over Latent Frequency	This terminal will be “action” when running frequency exceeds the set value of F119 (P <sub>23</sub> ). This terminal will restore when running frequency is lower than the value.
3	Free Stop	The terminal will be “action” when signal of “free stop” is input.
4	Inverter in Operation	The terminal will be “action” when inverter works. And it will restore when inverter stops.
5	During DC Braking	The terminal will be “action” when inverter is under DC braking.
6	Indicating Switchover of Acceleration / Deceleration	This terminal will be “action” when it carries out the instruction of “switchover of acceleration/deceleration”.

7	Reaching the Set Count Value	This terminal will be "action" when inverter carries the external count instruction and count value reaches the set value of F222 .
8	Reaching the Designated Count Value	This terminal will be "action" when inverter carries the external count instruction and count value reaches the set value of F224.
9	Overload Early Warning Signal	This terminal will be "action" and send a signal of overload protection early warning when the current reaches a certain value.
11	Indication function when reaching a certain frequency	When the output frequency is reached a certain value that is set by user, the corresponding programmable output terminal will give an indication signal
10, 12, 13	Reserved	

**5.4.3 Analog signal Output Terminal**

F418 FM Output Function Selection	Setting Range:	Mfr Value:0
	0: indicate output frequency value 1: indicate output current value	

·When selecting "indicate output frequency", 0 ~ 10V output corresponds to 0 ~ F111 (max frequency).

·When selecting "indicate input frequency", 0 ~ 10V output corresponds to 0 ~ I<sub>e</sub> ( inverter's rated current ) .

F419 FM Output Calibration ( % )	Setting Range: 0 ~ 200	Mfr Value:100
----------------------------------	------------------------	---------------

·This function is used to calibrate the output error of FM. Calibration value will be subject to the actual measuring.

F420 IM(FM)Output Range Selection	Setting Range:	Mfr Value: 0
	0: 0 ~ 20mA (0 ~ 10V) 1: 4 ~ 20mA (2 ~ 10V)	

·Proper selection of current output range (voltage) will be subject to different types of meters.

F422 Starting frequency that the indication function will be executed at	Setting Range: Max(5.00,F112)~F111	Mfr Value: 5.00
--	---------------------------------------	-----------------

·When the output frequency is reached a certain value that is set by user, the corresponding programmable output terminal will give an indication signal

·It is a supplement of function when F416(F417)=11

·When the output frequency is lower than this value, this function is invalid.

**5.5 V/F Control Parameters**

**5.5.1 V/F Compensation & Carrier Wave Frequency**

F500 Slip Compensation	Setting Range: 0.00 ~ 0.08	Mfr Value: 0.03
------------------------	----------------------------	-----------------

·Slip will gain in case of higher overload. Adjusting the parameter of F500 will make motor's actual rotate-speed close to the rated rotate-speed.

F501	V/F Curve Control Mode	Setting Range: 0: beeline 1: polygonal line 2: square	Mfr Value: 0
F502	Torque Promotion ( % )	Setting Range: 1 ~ MIN( 15 , F506 )	Mfr Value: 5

· This product has 3 control modes for “V/F” curve, to promote output torque at low frequency.

· Torque promotion can be set through F502 for selection of polygonal-line type V/F curve. Higher value setting will incur bigger compensation (as shown in Fig 5-7) ,and more starting current. Over-setting values may result in inverter’s over-current protection.

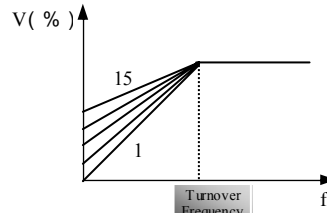

Fig 5-7 Torque Promotion

· Square V/F curve will meet requirements where blower and pumps are used.

· User may select polygonal-line type V/F curve for flexible setting if he has any special requirements for V/F curve.

· MIN(15, F506) refers to the smaller one of the two set values between 15 and F506.

F505	User-Defined Frequency Point 1 (Hz)	Setting Range: F112 ~ F507	Mfr Value: 10.00
F506	User-Defined Voltage Point 1 ( % )	Setting Range: F502 ~ MIN(100, F508)	Mfr Value: 30
F507	User-Defined Frequency Point 2 (Hz)	Setting Range: F505 ~ F118	Mfr Value: 20.00
F508	User-Defined Voltage Point 2 ( % )	Setting Range: F506 ~ MIN(100, F509)	Mfr Value: 40
F509	Voltage Corresponding Turnover Frequency ( % )	Setting Range: F508 ~ 100	Mfr Value: 100

· User may define on its own polygonal-line type V/F curve as per its requirements and actual load, as shown in Fig 5-8.

· MIN(100, F508) shows the smaller of the two set values between 100 and F508.

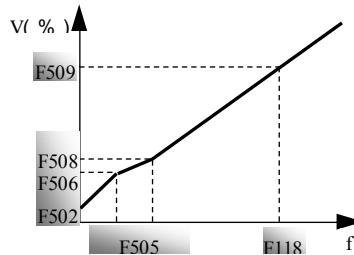

Fig5-8 Polygonal-Line Type V/F

F511	Auto Voltage adjusting	Setting Range: 0: no adjusting 1: adjusting	Mfr Value: 0
------	------------------------	--	--------------



·In case of fluctuation with input voltage, this function may automatically adjust ratio of PWM output to keep output voltage stable.

F512 Carrier-Wave Frequency Setting (kHz)	Setting Range: 1 ~ values set as per inverter model	Mfr Value: subject to inverter model
---	---	--------------------------------------

·Carrier-wave frequency is modulating-frequency when inverter outputs PWM wave.

· Promoting carrier-wave may improve output current-waveform, reduce motor noise, but the temperature of inverter will rise.

F513 Random Carrier-Wave Selection	Setting Range: 0: not allowed 1: allowed	Mfr Value: 1
------------------------------------	---	--------------

·F513 = 0: inverter will modulate as per the carrier-wave set by F512;

·F513 = 1: inverter will operate in mode of random carrier-wave modulating, which will reduce noise effectively.

### 5.5.2 Braking Parameters

F514 DC Braking Function Selection	Setting Range: 0: not allowed 1.braking during start 2.braking during stop 3.braking during start+stop	Mfr Value:0
F515 Initial Frequency of DC Braking (Hz)	Setting Range: 0.00 ~ 5.00	Mfr Value: 5.00
F516 DC Braking Current (%)	Setting Range: 0 ~ 150	Mfr Value: 100
F517 Braking Lasting Time During Starting (S)	Setting Range: 0.0 ~ 10.0	Mfr Value: 5.0
F518 Braking Lasting Time During Stopping (S)	Setting Range: 0.0 ~ 10.0	Mfr Value: 5.0

· In case of negative torque, using “pre-starting braking” may ensure that motor stays in quiescence before starting.

·Parameters related to “DC Braking”: F515, F516,

F517 and F518, with following interpretations:

a. F515: Initial-frequency of DC-braking.

DC braking will start when inverter’s output frequency is lower than this value.

b. F516: DC braking current. The ratio of current and rated current in case of

braking. The higher this value is, the higher braking torque is.

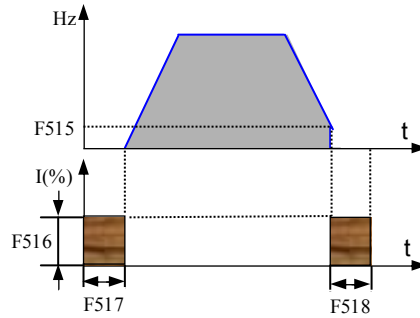

Fig 5-9 DC Braking

- c. F517: Braking lasting time when starting. The lasting time of DC braking before inverter starts.
- d. F518: Braking lasting time when stopping. The lasting time of DC braking in course of inverter's stopping.

·DC braking, as shown in Fig 5-9.

F519 Energy Consumption Brake Ratio (%)	Setting Range: 0 ~ 100	Mfr Value: 50
---	------------------------	---------------

·It means the ratio when power resistor is used in energy consumption braking. Higher value will lead to quicker energy consumption with motor feedback, which can effectively shorten inverter's deceleration time.

### 5.5.3 Stalling Adjusting

F525 Stalling Adjusting Function Selection	Setting Range: 0: not allowed 1: allowed	Mfr Value: 0
F526 Stalling Current Adjusting (%)	Setting Range: 120 ~ 200	Mfr Value: 160
F527 Stalling Voltage Adjusting (%)	Setting Range: 120 ~ 200	Mfr Value: 140

· Inverter automatically stops acceleration/deceleration at stalling, and will go on with acceleration / deceleration after output current or bus voltage drops. Stalling adjustment can avoid trip as inverter is accelerating / decelerating.

·Set stalling voltage properly for inverters without energy consumption resistor or braking unit to avoid over-voltage trip.

### 5.6 PI Adjusting Parameters

F600 PI Adjusting Function Selection	Setting Range: 0: not allowed 1: allowed	Mfr Value: 0
F601 PI Adjusting Channel Setting Selection	Setting Range: 0: Digital Setting 1: AN1 Channel Setting 2: AN2 Channel Setting	Mfr Value: 0
F602 PI Adjusting Digit Setting (V)	Setting Range: 0.00 ~ 10.00	Mfr Value: 5.00
F603 PI Adjusting Feedback Channel Selection	Setting Range: 0: AN1 channel feedback 1: AN2 channel feedback 2: OP1 pulse channel feedback	Mfr Value: 0

·Digit given is a target value (0 ~ 10V) for PI adjusting set by function code F602.

·Analog given (or feedback) will be achieved through analog channel AN1 and AN2 together with jumper terminal, including voltage analog and current analog. Refer to Use of Jumper Terminals (P<sub>27</sub>) for detailed operation;

·Pulse channel feedback means taking the pulse frequency input by terminal OP1 as feedback

(F408=23—P<sub>34</sub>).

F604	Min Analog Set by PI (V)	Setting Range: 0.00 ~ F606	Mfr Value: 0.00
F605	Corresponding Feedback for Min Analog Set by PI (V)	Setting Range: 0.00 ~ 10.00	Mfr Value: 0.00
F606	Max Analog Set by PI (V)	Setting Range: F604~10.00	Mfr Value: 10.00
F607	Corresponding Feedback for Max Analog Set by PI (V)	Setting Range: 0.00 ~ 10.00	Mfr Value: 10.00

·Set F604 ~ F607 as per the setting value scope and feedback scope of the close-loop adjusting system, as well as interrelation between setting value and feedback value. Normally setting is done as per the corresponding relation between setting and feedback meter.

·If thermo-regulation is made, regulation range is 20~100°C and setting range of the corresponding control system is 2~8V, and when temperature fluctuates within 20~100°C and output range of temperature measurement meter is 3~9V, then F604~F607 is set as follows:

F604=2.00, F606=8.00; F605=3.00, F607=9.00.

F608	Proportion Gain	Setting Range: 1 ~ 1000	Mfr Value: 100
F609	Integration Time (S)	Setting Range: 0.1 ~ 10.0	Mfr Value: 0.1
F610	Sampling Cycle (S)	Setting Range: 0.1 ~ 10.0	Mfr Value: 0.1

· Proportion Gain (P) and Integration Time (Ti) as shown in Fig 5-10. Sampling Cycle refers to that of feedback quantity x. Ti as shown here refers to Integration Time. The bigger Ti is, the slower the system responds; the smaller Ti is, the faster the system responds, but it is to surge. Contrariwise with Proportion Gain (P).

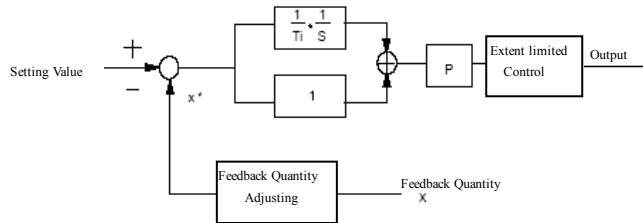

Fig 5-10 PI Adjusting

F611	PI Adjusting Accuracy (%)	Setting Range: 0 ~ 20	Mfr Value: 5
------	---------------------------	-----------------------	--------------

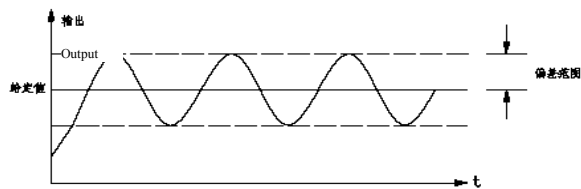

Fig 5-11 Deviation Range Allowed

· It refers to the percentage of the deviation (between feedback of PI regulation and setting value)  $\text{ag} \frac{\text{Setting Value}}{\text{Deviation Range}}$  close-loop given value. Deviation range allowed by PI regulation is shown in Fig 5-11.

F612	PI Regulating Polarity	Setting Range: 0: negative feedback adjusting 1: positive feedback adjusting	Mfr Value: 0
------	------------------------	--	--------------

·Negative feedback adjusting means that when regulation deviation is positive, PI adjusting will bring output frequency down.

·Positive feedback adjusting means that when regulation deviation is positive, PI adjusting will bring output frequency up.

## 5.7 Timing Control & Definable Protection Parameters

### 5.7.1 Timing Control

F700	Mode Selection for Free-Stop	Setting Range: 0:Stop immediately 1:Stop Delay	Mfr Value: 0
F701	Delay time of Free-Stop and Programmable Output Terminal's Action (S)	Setting Range: 0.0 ~ 60.0	Mfr Value: 0.0

· “Immediate Stop” means that inverter will stop output immediately when detecting “free stop” signal, and load will stop by inertia.

· “Delayed Stop” means that inverter will execute “free stop” command after waiting some time upon receiving “stop” instead of stopping immediately. Delay time is set by F701.

F702	Fan Control Selection (valid only for 18.5 ~ 110KW inverter)	Setting Range: 0: temperature controlled fan running 1: not temperature controlled fan running	Mfr Value: 0
------	--	--	--------------

·As F702 = 0, fan is controlled by radiator’s temperature during running. It will start to work when temperature reaches a certain value;

·As F702 = 1, fan is controlled by radiator’s temperature during running, i.e., fan will start to work when inverter is power connected.

F705	Allowed Auto-restart Times	Setting Range: 0 ~ 5	Mfr Value: 3
F706	Interval Time of Auto-restart(S)	Setting Range: 0.0 ~ 10.0	Mfr Value: 3.0

·When auto start is working, i.e., F139 = 1 (P<sub>25</sub>), set the times allowed for auto restart and interval time of

start after inverter is power-reconnected or malfunction protection.

**5.7.2 Settable Protection - Under-Voltage Protection and Overloading Protection**

F709	Under-Voltage Protection Value (V)	Setting Range: 200 ~ 420	Mfr Value: subject to inverter's model
------	------------------------------------	--------------------------	--

· As bus-voltage is lower than this set value, inverter will start undervoltage protection.

F715	Overloading Adjusting Gains	Setting Range: 0 ~ 1000	Mfr Value: Adjusting value
F716	Inverter Overloading Coefficient (%)	Setting Range: 150 ~ 180	Mfr Value: Adjusting value
F717	Motor Overloading Coefficient (%)	Setting Range: 20 ~ 120	Mfr Value: Adjusting value

· As output current is accumulated to overloading protection value, inverter will start “overloading protection”.

· Overloading Adjusting Gains (F715): the time constant of the response speed of overload protection, which is used to regulate the speed of frequency decreasing. The bigger gains are, the slower frequency decrease.

· Inverter Overloading Coefficient (F716): the ratio of overload-protection current and rated current when overload protect occurs. Its value shall be subject to actual load.

· Motor Overloading Coefficient (F717): Set as follows in order to protect motor when inverter is running with lower-power motor:

$$F717 : \text{Motor Overloading Coefficient} = \frac{\text{Actual Motor Power}}{\text{Proper Motor Power for Inverter}} \times 100\%$$

**5.7.3 Trouble Recording**

F720	Third Malfunction Type By Counting Down	0: No Trouble 1: Acceleration Over-Current 2: Deceleration Over-Current 3: Constant-Speed Over-Current 4: Acceleration Over-Voltage 5: Deceleration Over-Voltage 6: Constant-Speed Over-Voltage 7: Undervoltage 9: Inverter Overload 10: Motor Overload 11: Excess Temperature
F721	Second Malfunction Type By Counting Down	

F722	The Latest Malfunction Type	12: User's Password Error / Serious Exterior Interference 13: Out-Phase 15: Emergency Stop 19: Galvanoscopy Error 21: Peripheral Equipment Malfunction
F723	The Latest Malfunction Frequency (Hz)	
F724	The Latest Malfunction Current (A)	
F725	The Latest Malfunction Voltage (V)	

·F720 ~ 725 is used to record the latest three malfunction types and the corresponding frequency, current and voltage at last malfunction.

Refer to Appendix 1(P<sub>55</sub>) for causes and countermeasures for any malfunction.

## 5.8 Analog signal Parameters

### 5.8.1 Analog signal Input

In mode of analog speed control, it is necessary to set the min and max input analog, and the corresponding output frequency to secure a good speed control effect.

F800	Min Analog Input (V)	Setting Range: 0.00 ~ MIN(F801,10.00)	Mfr Value: 0.00
F801	Max Analog Input (V)	Setting Range: MAX ( 0.00 , F800 ) ~ 10.00	Mfr Value: 10.00
F807	Corresponding Frequency for Min Analog (Hz)	Setting Range: F112 ~ F111	Mfr Value: 0.00
F808	Corresponding Frequency for Max Analog (Hz)	Setting Range: F112 ~ F111	Mfr Value: 50.00

·Set min and max analogs as per actual input range of analog signal.

·The setting values of F807 and F808 decide proportion mode of analog adjustment change, as shown in Fig 5-12:

·MIN (F801, 10.00) refers to the smaller one of the two values between F801 setting value and 10.00.

·MAX (0.00, F800) refers to the bigger one of the two values between F800 setting value and 0.00.

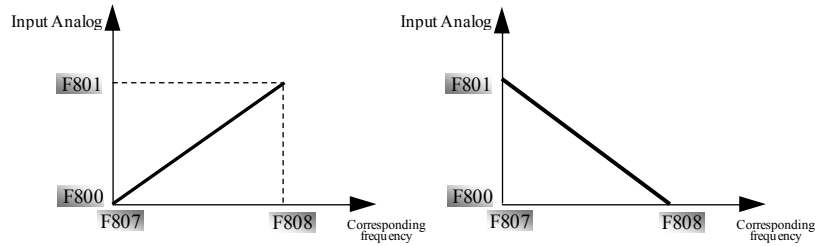

Fig 5-12 Proportion Mode of Analog Adjusting

**5.8.2 Pulse Frequency Input**

F809	Max Input Pulse Frequency (Hz)	Setting Range:0 ~ 9999	Mfr Value: 5000
F810	Corresponding Frequency for Max Input Pulse Frequency (Hz)	Setting Range: 0.00 ~ F111	Mfr Value: 50.00

·As F204 = 7 (P<sub>26</sub>) and F408=23 (P<sub>34</sub>), inverter’s running frequency can be controlled through pulse frequency input by OP1 terminal.

·F809 provides the max pulse frequency allowed for inverter’s input. Inverter will not proceed in case of exceeding this frequency.

F811	Filtering Time Constant (S)	Setting Range: 1.0 ~ 10.0	Mfr Value: 3.0
------	-----------------------------	---------------------------	----------------

·Filter the input analog signal. The bigger the value is, the steadier the analog set frequency is, but will have a slow response.

**5.9 Communication Parameters**

F900	485 Communication Interface Function Selection	Setting Range: 0: computer 1:485 Communication Control Enclosure	Mfr Value: 1
------	--	---	--------------

·This function is used for selecting inverter’s communication type:

0: Computer will communicate and control inverter through 485 interface.

1: “Communication Control Enclosure 485” works and controls inverter through 485. It will take 9600 bit (F903 = 3) as default communication Baud rate in this control mode, which can not be changed.

F901	Communication Address	Setting Range: 1 ~ 127: inverter address	Mfr Value: 1
------	-----------------------	--	--------------

·Set the communication address for inverter. Each address in the same connection net shall be exclusive and unrepeatable.

F902	Odd/Even Calibration	Setting Range: 0: no calibration	Mfr Value: 0
------	----------------------	----------------------------------	--------------

	1:odd calibration 2:even calibration	
--	---	--

·Select calibration type for RS-485 communication.

·As F900 = 1, this function does not work.

F903 Communication Baud Rate (bit)	Setting Range: 1:2400 2:4800 3:9600 4:19200	Mfr Value: 3
------------------------------------	--	--------------

·Selecting data transmission ratio between inverter and computer remote control.

·As F900 = 1, “Communication Control Enclosure 485” will take 9600bit as default communication Baud rate, which can not be changed.

F904 No Parameter Mode	Setting Range: 0: Run with parameters 1: Run without parameters	Mfr Value: 1
------------------------	--	--------------

F904 is only valid for the computer remote control mode(F200=2).

F904=0; run with the parameters which receive from the PC.

F904=1;run with the parameters which are set by panal. The parameters received from the PC is not valid.



## VI. Simple Mode of Operation

### 6.1 Operation Mode Block Diagram

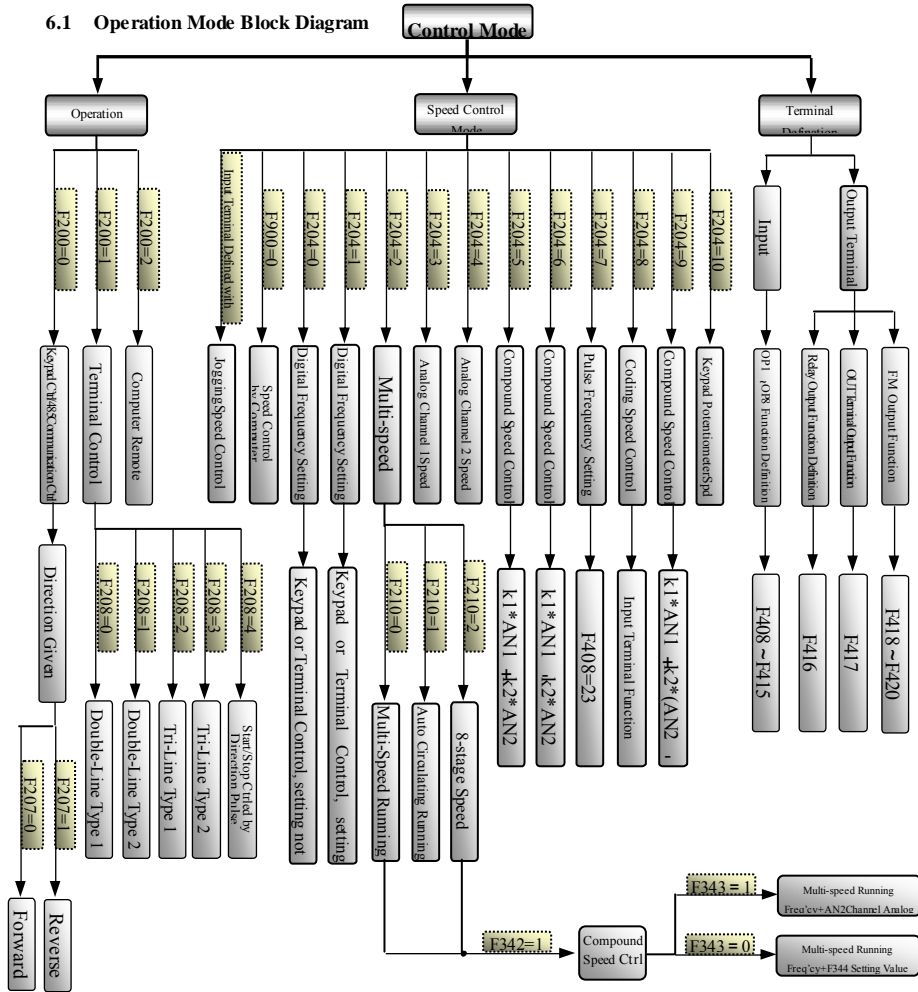

Fig 6-1 Operation Mode Block Diagram

### 6.2 Speed Control

F1500-G series inverter has multiple ways of speed control like “*keypad and terminal digital speed control*”, “*multi-speed control (including multi-speed running, automatic circulating running, 8-stage speed*”

*running, compound speed control”, “analog signal single channel speed control”, “analog signal compound speed control”, “coding speed control”, “jogging speed control” and “computer speed control” and so on.* All these must **correspond with parameter settings**, to be detailed as follows:

### **1) Keypad, Terminal Digital Speed Control: F204 = 0 or 1**

Under this setting, inverter adopts the way of keypad, terminal digital speed control, and speed can be adjusted with “▲ /▼ ” keys on the keypad or “UP” and “DOWN” terminals to achieve dynamical speed control. Among which the function of “UP” and “DOWN” terminals speed control is defined by F408 ~ F415 and “UP” terminal equals to “▲ ” key on the keypad and “DOWN” terminal equals to “▼ ” key on the keypad.

e.g. as F409=11, OP2 is defined as “UP” terminal that is connected with CM and frequency rises; as F410=12, OP3 is defined as “DOWN” terminal, that is connected with CM and frequency drops.

As F204 = 0, no adjusting result is saved after inverter is suddenly turned off;

As F204 = 1, adjusting result is saved after inverter is suddenly turned off;

Manufacturer’s default speed-control mode is F204 = 0.

Operation control is selected by F200: F200 = 0 keypad control/485 communication control, F200 = 1 terminal control , F200 = 2 computer control ( P<sub>25</sub> ) .

Operation direction of keypad control is selected by F207: F207 = 0 forward, F207 = 1 reverse (P<sub>28</sub>).

Terminal control way is selected by F208: F208 = 0 ,two-line type 1; F208 = 1 , two-line type 2; F208=2, three-line type 1; F208=3 , three-line type 2, F208 = 4 start/stop controlled by direction pulse (P<sub>28</sub>).

Frequency adjusting step length is set by F230 with setting scope of 0.01 ~ 1.00Hz (P<sub>31</sub>)

Stopping mode is selected by F121: F121 = 0 stop by deceleration time, F121 = 1 free stop. Free stop is selected by F700: F700 = 0 stop at once, F700 = 1 delayed stop. F701 (P<sub>39</sub>) sets delayed stop time.

### **2) Multi-Speed Control: F204 = 2**

Multi-speed control is further divided into 4 modes: multi-speed running, automatic circulating running, 8-stage speed running and compound stage speed running, which is selected by F210: F210=0 multi-speed running, F210 = 1 automatic speed running, F210 = 2 8-stage speed running (P<sub>29</sub>).

Stage-speed changing control is done by F209: F209 = 0 allows no adjustment to segment speeds, F209 = 1 allows adjustment to segment speeds (P<sub>29</sub>).

Multi-segment-speed's related parameters are set by F300 ~ F344(P31).

Operation control is selected by F200: F200 = 0 keypad control/485communication control, F200 = 1 terminal control , F200 = 2 computer control ( P25 ) .

Terminal control mode is selected by F208: F208 = 0 ,two-line type 1; F208 = 1 , two-line type 2; F208=2, three-line type 1; F208=3 , three-line type 2, F208 = 4 start/stop controlled by direction pulse (P28).

Adjustment step length of frequency is set by F230. Setting range is 0.01 ~ 1.00Hz(P31).

Stop mode is selected by F121: F121 = 0 stop by deceleration time, F121 = 1 free stop. Free stop is selected by F700: F700 = 0 stop at once, F700 = 1 delayed stop. F701 (P39) sets time of delay stop.

**a. Multi-Speed Running: F204=2, F210=0**

“Multi-speed” involves 7 speeds (their frequency values, acceleration and deceleration time and so on can be revised via parameters) set in the inverter and is operated by defined “multi-speed terminal 1”, “multi-speed terminal 2” and “multi-speed terminal 3”. The status combination that they are connected or disconnected with “CM” can call separately any speed of the “multi-speed”.

e.g., F408=1, F409=2, F410=3, then OP1, OP2, OP3 are separately defined as “multi-speed terminal 1”, “multi-speed terminal 2” and “multi-speed terminal 3”. See Table 6-1 for how to make compound calls:

Table 6-1 Multi-Speed Calling & Corresponding Parameters Setting

Multi-speed terminal 3	0	0	0	0	1	1	1	1
Multi-speed terminal 2	0	0	1	1	0	0	1	1
Multi-speed terminal 1	0	1	0	1	0	1	0	1
Stage speed Calling	Stop	1st Speed	2nd Speed	3rd Speed	4th Speed	5th Speed	6th Speed	7th Speed
Acceleration time		F301	F307	F313	F319	F325	F331	F337
Deceleration time		F304	F310	F316	F322	F328	F334	F340
Frequency Set		F302	F308	F314	F320	F326	F332	F338
Operation direction	keypad control (F200=0)	F300	F306	F312	F318	F324	F330	F336
	terminal control (F200=1)	Realized by the control mode of terminals FWD, REV, and X (F208)						

Note: “1” in the table means the terminal of input signal is connected with CM; “0” means the terminal of input signal is disconnected with CM.

**b. Automatic circulating operation: F204=2, F210=1**

“Automatic circulating operation” means “multi-segment-speed” automatic circulating operation, i.e., inverter shall automatically operate as per acceleration/deceleration time, operation time, operation frequency and operation direction set in “each stage speed” as required by users after “operation” command is given; when operation reaches the set time value, inverter shall automatically switch among stage speeds. During the operation, inverter shall continuously operate according to the set parameters if no command of “stop” is given or it doesn’t reach the set value by F212 (operation times of auto circulation).

“Auto circulating operation” can be called by “run” key or the defined “operation” terminal and can be automatically removed by the setting of F212 or by “stop” key on the keypad or the defined “stop” terminal.

“Auto circulating operation” can realize auto circulating operation of 2nd~ 7th speeds (set by F211). Once the times of circulation is reached (set by F212), inverter shall stop automatically or remain in stable operation at the final stage speed frequency (set by F213).

e.g: F211 = 7, select auto circulating operation of “7-stage speed”. F212 = 1000, automatic circulating operation for 1000 times. F213 = 0, it automatically stops after circulating operation end.

As the F1500-G inverter is carrying the function of “auto-circulating operation”, it shall directly switch from current speed to the next speed (as shown in Fig 6-2)

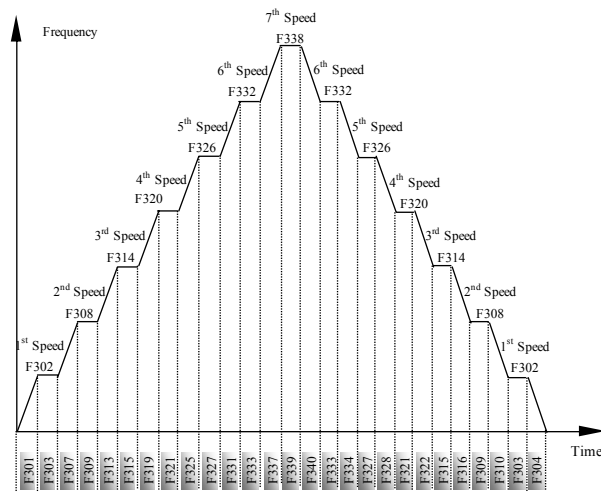

Fig 6-2 Auto-Circulating Operation (stop/wait time=0)

without stopping and waiting if stopping and waiting time equals to zero, i.e., the setting of F305, F311, F317, F323, F329, F355 and F341 is 0.0.

If “ Stop/wait time” is more than 0, i.e., the values of F305, F311, F317, F323, F329, F355 and F341 are set

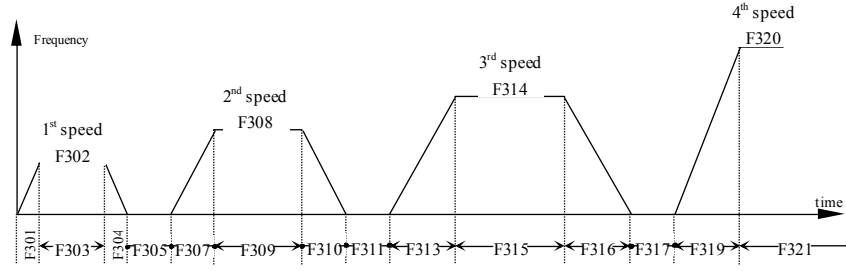

Fig 6-3 Auto-Circulating Operation (stop/wait time>0)

more than 0.0, inverter shall first stop waiting and then switch to the next speed (as shown in Figure 6-3)

If the operation direction among stage speeds is different, like F300 = 0, F306 = 1, F312 = 0, then the switch process of speeds shall be stop first before switch to the next speed and the switch process shall carry out the death area time of forward and reverse switch (F120—P23), as shown in Fig 6-4.

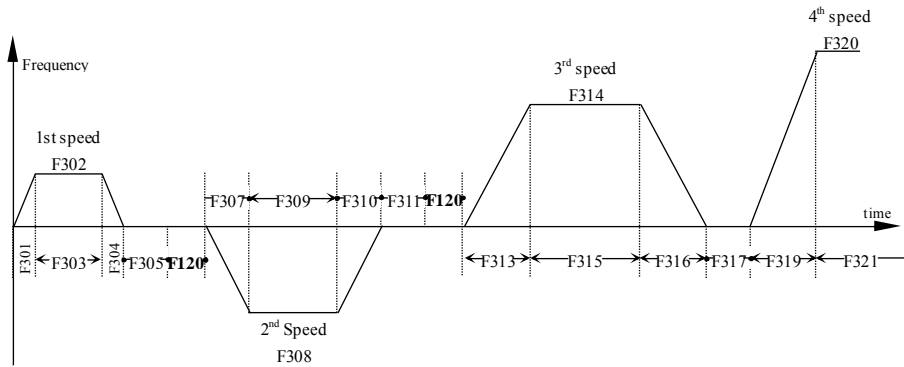

Fig 6-4 Auto-Circulating Operation (different operation direction between segment speeds)

**c. 8<sup>th</sup> Speed Operation: F204 = 2, F210 = 2**

The 8-stage speed operation consists of 7 speed frequencies and the target frequency F113, which are also operated by the defined “multi-speed terminal 1”, “multi-speed terminal 2” and “multi-speed terminal 3”. The status combination that the 3 terminals are connected or disconnected with “CM” can call separately any of the 8 speeds.

e.g.: F408=1, F409=2 and F410=3, the terminals of OP1, OP2 and OP3 are separately defined as “multi-speed terminal 1” “multi- speed terminal2”and“multi- speed terminal 3”.

See Table 6-2 for how to make compound call:

Table 6-2 8-Speed Calling & Its Corresponding Parameter Setting

Multi-speed terminal 3	0	0	0	0	1	1	1	1
Multi-speed terminal 2	0	0	1	1	0	0	1	1
Multi-speed terminal 1	0	1	0	1	0	1	0	1
Stage-Speed Calling	1 <sup>st</sup> Speed	2 <sup>nd</sup> Speed	3 <sup>rd</sup> Speed	4 <sup>th</sup> Speed	5 <sup>th</sup> Speed	6 <sup>th</sup> Speed	7 <sup>th</sup> Speed	8 <sup>th</sup> Speed
Acceleration time	F114	F301	F307	F313	F319	F325	F331	F337
Deceleration time	F115	F304	F310	F316	F322	F328	F334	F340
Frequency Set	F113	F302	F308	F314	F320	F326	F332	F338
Operation direction (F200 = 0 )	keypad control	F207	F300	F306	F312	F318	F324	F330
Operation direction (F200 = 1 )	terminal control	Realized by the control mode of terminals FWD, REV, and X (F208)						

Note: “1” in the table means input signal terminal is connected of with CM; whereas “0” means disconnection of input signal terminal from CM.

**d. Compound on speed control: F204 = 2, F210 = 0 or 2, F342 = 1**

Compound speed control means the speed control mode controlled jointly by multi-speed control, digital speed control and analog speed control. This speed control mode is only effective to multi-speed and 8-stage speed running but is not valid to auto circulating operation.

When jointly controlled by multi-speed control and digital speed control (F343 = 0—P32), the running frequency of each speed will be the total of multi-speed setting frequency and the setting value of digital frequency. The setting value of digital frequency is set by F344 with a range of 0.00 ~ 20.00Hz.

When jointly controlled by multi-speed control and analog speed control(F343 = 1—P32), the operation frequency of each speed is the total values set by multi-speed frequency and AN2 channel analog signal whose value is set at the range of 0~ 10V ( provided through AN2 channel by peripheral equipment) corresponding with a range of 0 ~ 12Hz.

Stage-speed changing control is selected by F209: F209 = 0 not allowed to changing to stage speed; F209 = 1 allowed to changing to stage speed (P29).

The related parameter of multi-speed is set by F300 ~ F344 ( P31 ) .

Operation control is selected by F200: F200 = 0 keypad control/485 communication control; F200 = 1 terminal control; F200 = 2 computer remote control(P25).

Operation direction of keypad control is selected by F207: F207 = 0 forward, F207 = 1 reverse(P28).

Terminal control mode is selected by F208: F208 = 0 ,two-line type 1; F208 = 1 , two-line type 2; F208=2, three-line type 1; F208=3 , three-line type 2, F208 = 4 start/stop controlled by direction pulse (P<sub>28</sub>).

The adjustment step length of frequency is set by F230 with the range of 0.01 ~ 1.00Hz (P31).

Stop mode is selected by F121: F121=0 stop by deceleration time, F121=1 free stop, which is chosen by F700: F700=0 stop immediately, F700 = 1 delayed stop. F701 (P39) sets delay stop.

### 3) Single channel analog signal speed control: F204=3, 4 or 10 Note3

Analog speed control means to adjust inverter's output frequency by the analog signal of voltage (or current), during which, voltage analog signal can be defined by the external potentiometer or that of the keypad control unit, or it can also be defined by output analog signal of other facilities. Current analog signal can be defined by corresponding sensors or by output of other control facilities.

As F204=3, The speed control signal of analog signal shall be input by terminal "AN1"; as F204=4, speed control signal of analog signal shall be input by terminal "AN2"; F204 = 10 is used to select the control speed of the analog signal of keypad potentiometer (Vk) Note 3. (Note 3: No "J2" jumper terminals with both single-phase inverters without built-in braking unit and 3 phase 11 ~ 110KW inversion. Analog signal of keypad potentiometer (Vk) is set by function code of F204.)

Different ways of speed control can be reached by using jumper terminals and function parameter settings together (see details on P27 for Application of Jumper Terminals.)

Related parameters of analog signal are set by F800 ~ F811(P44).

Operation control is selected by F200: F200 = 0 keypad control/485 communication control, F200 = 1 terminal control, F200 = 2 computer remote control (P25).

Operation direction of keypad control is selected by F207: F207 = 0 forward , F207 = 1 reverse ( P28 ) .

Terminal control mode is selected by F208: F208 = 0 ,two-line type 1; F208 = 1 , two-line type 2; F208=2, three-line type 1; F208=3 , three-line type 2, F208 = 4 start/stop controlled by direction pulse (P<sub>28</sub>).

Stop mode is selected by F121: F121 = 0 stop by deceleration time, F121 = 1 free stop. Of which free stop mode is selected by F700: F700 = 0 immediate stop, F700 = 1 delayed stop. Time of delayed stop is set by F701(P39).

#### 4) Compound Speed Control of Analog signal: F204 = 5, 6 or 9

For compound speed setting, analog signal is input through terminals of "AN1" and "AN2". For F204=5, the result of compound speed control is  $k1 * AN1 + k2 * AN2$ ; as F204=6, the result of compound speed control is  $k1 * AN1 - k2 * AN2$ ; as F204=9, the result of compound speed control is  $k1 * AN1 + k2 * (AN2 - 5V)$ . The "AN1" and "AN2" in the formula mean the analog signal input through channels AN1 and AN2.

For compound speed control, there is a function with the programmable input terminal (OP1 ~ OP8), which may be used to switch the controls of dual-way analog signal and single-way analog signal. For single-way analog signal control, AN1 channel control is considered valid by default. For instance F409 = 20: when OP2 is disconnected from CM, it is dual-way analog signal control; when OP2 is connected with CM, AN1 channel control works, equal to F204 = 3.

Different speed control mode may be realized by using jumper terminals and function parameter settings together (refer to Application of Jumper Terminal on P27 for details)

Ratio coefficients k1 and k2 are set by F214 and F215 functional code (P30).

Related parameters of analog signal is set by F800 ~ F811(P44).

Operation control is selected by F200: F200 = 0 keypad control/485communication control, F200 = 1 terminal control, F200 = 2 computer remote control (P25).

Operation direction of keypad control is selected by F207: F207 = 0 forward , F207 = 1 reverse ( P28 ) .

Terminal control mode is selected by F208: F208 = 0 ,two-line type 1; F208 = 1 , two-line type 2; F208=2, three-line type 1; F208=3 , three-line type 2, F208 = 4 start/stop controlled by direction pulse (P28).

Stop mode is selected by F121: F121 = 0 stop as deceleration time, F121 = 1 free stop. Of which, free stop mode is selected by F700: F700 = 0 immediate stop, F700 = 1 delayed stop. F701 (P39) sets time of delayed stop.

#### 5) Coding Speed Control: F204=8

Set the input terminal (OP1 ~ OP8) as the coding speed control function. The different switch status combinations for terminal mean the 8-binary data. OP8 is the highest bit. and OP1 is the lowest bit. It is further stipulated that connection between terminal and "CM" is binary 1 and disconnecting with "CM" is binary '0'.

Through inverter, the 8-binary data input by OP1 ~ OP8 shall be changed to decimal system value, the ratio with value 255 will then multiply with inverter's max frequency and get the actual output frequency of



coding speed control.

e.g.: if max frequency F111 = 50.00Hz, F415=18 and OP8 terminal connects with CM terminal, then input binary data 10000000, which is 128 in decimal. The operation frequency will therefore be  $(128 / 255) \times 50 = 25.10\text{Hz}$ .

6) Jogging Speed Control: F200 = 1

In mode of terminal control (F200 = 1), when function of certain programmable input terminal (OP1 ~ OP8) is defined as jogging function, jogging speed control can be reached by short connection of the terminal with CM.

The jogging frequency is set by F124 with range: F112 ( min frequency) ~ F111( max frequency).

The jogging acceleration /deceleration time is set by F125 and F126, with range of 0.1 ~ 3000S.

The direction of jogging operation is included in the definition for terminal function: 9 is forward running and 10 is reverse running.

Stop mode is selected by F121: F121 = 0 stop as deceleration time, F121 = 1 free stop. Of which, free stop is selected by F700: F700 = 0 instant stop, F700 = 1 delayed stop. F701 (P42) sets delayed stop time.

7 ) Computerized Speed Control: F900 = 0

Computerized speed control means that computer will communicate via 485 to control the operation of inverter.

The communication address is selected by F901 with setting range of 1 ~ 127. It should be noted that computer's "broadcasting address" is 255. When implementing the broadcasting command, computer may control all inverters in the network with no need for inverters to set broadcasting address.

Communication checking type is selected by F902: F902 = 0 non- checking, F902=1 odd checking, F902 = 2 even checking.

Communication Baud rate is set by F903: 2400bit for F903 = 1, 4800bit for F903 = 2, 9600bit for F903 = 3, and 19200bit for F903 = 4.

Stop mode is selected by F121: F121 = 0 stop by deceleration time, F121 = 1 free stop. Of which, free stop is selected by F700: F700 = 0 instant stop, F700 = 1 delayed stop. F701 (P39) sets delayed stop time.

## Appendix 1 Troubleshooting

When malfunction occurs to inverter or motor, users may get the type of malfunction, the bus voltage, output current and frequency of the moment that malfunction occurs through reading F720 ~ F725, and carry out inspection and analysis according to the following table or contact manufacturer when necessary.

Table 1 Malfunctions & Solutions

Malfunction Display	Description	Causes	Solutions
OC1	Acceleration over-current	Acceleration time too short	Prolong acceleration time
		Short circuit on the side of output	Motor cable damaged or not; motor insulation level is satisfactory to requirement or not
		Inverter's power is small	Select bigger power inverter
		Improper selection of V/F curve	Adjust V/F curve as per actual load; Reduce V/F compensation value
		Restart the motor in rotation	Restart when motor completely stops
		Overloaded	Reduce load
OC2	Deceleration over-current	Too short for deceleration time	Extend deceleration time
		high load inertia	Add proper energy consumption braking parts
OC3	Constant over-current	Short circuit on the side of output	Check if motor cable is damaged
		Sudden change of loading	Reduce sudden change of loading
		Abnormal loading	Check the loading
OE1	Acceleration overvoltage	higher input voltage	Check if the input voltage is normal
OE2	Deceleration overvoltage	Too short time for deceleration (compared to the capacity of regeneration)	Extend deceleration time
		high load inertia	Add proper energy consumption braking part
OE3	Over voltage of constant speed	Abnormal change of input voltage	Check input voltage or add reactor
		Big loading inertia	To add proper energy consumption braking parts
AdEr	Galvanoscopy malfunction	The wire or inserting parts between control PCB and power PCB gets loose	Check and reconnection
		Galvanoscopy elements damaged	Seek manufacturers' service
OL1	Inverter overloading	Too much overload	Reduce load
		Acceleration time too short	Extend acceleration time
		Improper V/F curves	Adjust the V/F curve, and properly lower compensation value
		Too much DC braking	Reduce DC braking current, extend braking time
		Inverter power small	Select inverter with bigger power

Table 1 continued

## Malfunctions &amp; Solutions

Malfunction display	Description	Causes	Solutions
<b>OL2</b>	Motor overload	Improper V/F curve	Adjust the V/F curve, and properly lower compensation value
		General motor runs at low speed with big load for long time	Special motor is needed for long time low speed running.
		Rotation of motor is jammed or loading suddenly gets bigger.	Reduce loading or the sudden change of loading
		Incorrect setting for motor overloading protection coefficient	Correctly set the protection coefficient for motor overloading
<b>PEr</b>	Out-phase protection	Out-phase with 3- phase power input	Check if power input is normal; Check the wiring is correct
		Serious imbalance with 3-phase input power	Check if power input is normal
		Power off unexpectedly with inverter's input power.	Normal indication
<b>LU</b>	Undervoltage protection	slightly low with input voltage	Check if voltage is correct
		Power off unexpectedly with inverter input power	Normal indication
<b>ESP</b>	External emergency stop	Press "stop/reset" key not in mode of keypad control (F200≠ 0)	Correctly set the functional parameters for F201& F200
		"External Emergency stop" terminal closes	Disconnect malfunction terminal after removal of external malfunction; Change the function of "programmable input terminal"
		Press "stop/reset" in case of stalling	Normal indication
<b>ErP</b>	Peripheral equipment malfunction	Terminal of "Peripheral equipment malfunction" closes	Disconnect malfunction terminal after removal of external malfunction; Change the function of "programmable input terminal"
<b>Err</b>	Wrong user's password	Wrong input of user's password ( F100 )	Input user's password again
	Serious external interference	Strong electromagnetic interference with inverter's surroundings	Check if the surroundings are satisfactory for use of inverter as required in 3.1.2
<b>OH</b>	Over temperature	Too high surrounding temperature	Reduce surrounding temperature
		Fan damaged	Change the fan
		Installation position is not fit for ventilation	Install as per manual and improved ventilation
		Radiators too dirty	Clean the inlet and outlet and the radiators
		Power module is abnormal	Seek manufacturers' service
<b>Cb</b>	Contactor does not suck	Too low voltage of power network	Check the voltage
		Contactor damaged	Change the main-loop contactor
		Trouble with the control loop	Seek manufacturers' service

Table 1 continued

## Malfunctions &amp; Solutions

Malfunction display	Description	Causes	Solutions
- Er -	Communication malfunction	Baud rate setting is incorrect when communicating with 485 communication control enclosure	Change inverter's Baud rate to manufacturer's value
		Incorrect communication address setting	Unify inverter address with 485 communication control enclosure
		Malfunction occur with communication circuits	Seek manufacturers' service
Motor doesn't work		Abnormal power-network voltage	Check if power-network voltage is normal
		Wrong wiring	Check the wiring
		Overloading	Reduce loading
Power tripping		Short circuits on input side	Check the input wiring
		Too small capacity of air switch	Increase air switch capacity
		Overloading	Reduce loading
Motor works but unable to control speed		Error setting for related parameters	Correctly set related parameters as to parameter description
		Serious overloading	Reduce loading
Instable rotation of motor		Sudden increase of overloading	Reduce the change of loading
		Power of inverter is slightly small	Select inverter of bigger power
		Serious electromagnetic interference	Check if surroundings is satisfactory for use of inverter as required in 3.1.2

**Appendix 2 Function Code Zoom Table**

Class	Function Code	Definition	Setting Range	Mfr Value	Note
Basic Parameters	F100	User's Code	0 ~ 9999	8	√
	F101	Reserved			
	F102	Inverter's Rated Current (A)		Subject to inverter model	□
	F103	Inverter Power (KW)	0.20 ~ 110.0	Power value of this inverter	□
	F104	Reserved			
	F105	Software Edition No.		Subject to software edition	□
	F106	Inverter's Input Voltage Type	1:single phase 3:three phase	Subject to inverter model	□
	F107	Inverter's Rated Input Voltage (V)	220 or 380	Subject to inverter model	□
	F108 ~ F110	Reserved			
	F111	Max Frequency (Hz)	F112 ~ 400.0	60.00	×
	F112	Min Frequency (Hz)	0.00 ~ MIN ( 50.00 , F111 )	0.00	×
	F113	Digital Setting Frequency (Hz)	F112 ~ F111	50.00	√
	F114	1 <sup>st</sup> Acceleration Time (S)	0.1 ~ 3000	20.0	√
	F115	1 <sup>st</sup> Deceleration Time (S)	0.1 ~ 3000	20.0	√
	F116	2 <sup>nd</sup> Acceleration Time (S)	0.1 ~ 3000	20.0	√
	F117	2 <sup>nd</sup> Deceleration Time (S)	0.1 ~ 3000	20.0	√
	F118	Turnover Frequency ( Hz )	50.00 ~ 400.0	50.00	×
	F119	Latent Frequency ( Hz )	F112 ~ F111	5.00	√
	F120	Forward/Reverse Switchover Dead-Time (S)	0.0 ~ 3000	2.0	√
	F121	Stopping Mode	0: stop by deceleration time 1: free-stop	0	×
	F122	Reverse Running Forbidden	0: null 1:valid	0	×
	F123	Reserved			
	F124	Jogging Frequency (Hz)	F112 ~ F111	5.00	√
	F125	Jogging Acceleration Time (S)	0.1 ~ 3000	20.0	√
	F126	Jogging Deceleration Time (S)	0.1 ~ 3000	20.0	√
	F127	Skip Frequency A (Hz)	0.00 ~ F111	0.00	×
	F128	Skip Width A ( Hz )	0.00 ~ 5.00	0.00	×
	F129	Skip Frequency B (Hz)	0.00 ~ F111	0.00	×

Class	Function Code	Definition	Setting Range	Mfr's Value	Note
Basic Parameters	F130	Skip Width B (Hz)	0.00 ~ 5.00	0.00	×
	F131	Displays	1 ~ 127 1: Frequency 2: Rotate Speed 4: Count Value 8: Output Current 16: Function-Code Editing 32: Output Voltage 64: Linear Velocity 127: Display All	127	√
	F132	Number of motor pole pairs	1 ~ 6	2	×
	F133	Driven system's drive ratio	0.1 ~ 100.0	1.0	×
	F134	Transmission-wheel radius (m)	0.001 ~ 1.000	0.001	×
	F135 ~ F138	Reserved			
	F139	Whether to start automatically after reconnection to power or malfunction	0:null 1:valid	0	×
	F140 ~ F159	Reserved			
	F160	Reverting to manufacturer values	0:Not reverting to manufacturer values 1:Reverting to manufacturer values	0	×
Running control parameters	F200	Operation Control	0:Keypad Control/485 Communication Control 1: Terminal Control 2: ComputerRemote Control	0	×
	F201	 Key Functions	0: valid only in mode of keypad control 1: valid in any modes 2: valid at time of keypad 3-line control, controlling start/stop by direction pulse and computer remote control	0	×
	F202、F203	Reserved			
	F204	Basic Speed Control Modes	0: Setting digital frequency, setting keypad and terminal UP & DOWN, not saving result when power off 1: Setting digital frequency, setting keypad and terminal UP & DOWN, saving result when power off 2: Multi-speed control 3: Analog channel 1 (AN1) speed control 4: Analog channel 2 (AN2) speed control 5: Analog Channel Compound speed-control 1: K1*AN1+K2*AN2 6: Analog Channel Compound speed-control 2: K1*AN1 - K2*AN2 7: Speed control set by pulse frequency 8: Code speed control 9: Analog Channel Compound speed-control 3: K1*AN1+K2*(AN2-5V) 10: Keypad potentiometer speed -control selection <small>Note3</small>	0	×

Class	Function Code	Definition	Setting Range	Mfr's Value	Note	
Running Control parameters	F205, F206	Reserved				
	F207	Keypad Direction Set	0: Forward 1: Reverse	0	√	
	F208	Terminal control mode	0: two-line type 1 1: two-line type 2 2: three-line type 1 3: three-line type 2 4: Start/stop controlled by direction pulse	0	×	
	F209	Stage-speed-Changing	0: Adjustment stage-speed forbidden 1: Adjusting stage-speed allowed	0	×	
	F210	Stage-Speed Types	0: Multi-stage speed running 1: Auto circulation running 2: 8 <sup>th</sup> -stage speed running	0	×	
	F211	Auto Circulation Running Speed Selection	2 ~ 7	7	×	
	F212	Auto Circulation Running Times Selection	0 ~ 9999	0	√	
	F213	Free Running Selection after Auto Circulation Running	0: Stop 1: Keep running at last stage speed	0	√	
	F214	k1	0.0 ~ 10.0	1.0	√	
	F215	k2	0.0 ~ 10.0	1.0	√	
	F216 ~ F220	Reserved				
	F221	Count Frequency Divisions	1 ~ 1000	1	×	
	F222	Set Count Times	F224 ~ 9999	1	×	
	F223	Reserved				
	F224	Designated Count Times	1 ~ F222	1	×	
	F225 ~ F229	Reserved				
	F230	Frequency setting Step Length (Hz)	0.01 ~ 1.00	0.01	×	
	F231 ~ F260	Reserved				
	Multi-Speed Parameters	F300	1 <sup>st</sup> stage-Speed Running Direction	0: Forward 1: Reverse	0	√
		F301	1 <sup>st</sup> stage-Speed Acceleration Time	0.1 ~ 3000	20.0	√
F302		1 <sup>st</sup> stage-Speed Running Frequency	F112 ~ F111	5.00	√	
F303		1 <sup>st</sup> stage-Speed Running Time	0.1 ~ 3000	20.0	√	
F304		1 <sup>st</sup> stage-Speed Deceleration Time	0.1 ~ 3000	20.0	√	
F305		1 <sup>st</sup> stage-Speed Stop/Waiting Time	0.0 ~ 3000	0.0	√	

Class	Function Code	Definition	Setting Range	Mfr's Value	Note
Multi-Speed Parameters	F306	2 <sup>nd</sup> stage-Speed Running Direction	0: Forward 1: Reverse	1	√
	F307	2 <sup>nd</sup> stage-Speed Acceleration Time	0.1 ~ 3000	20.0	√
	F308	2 <sup>nd</sup> stage-Speed Running Frequency	F112 ~ F111	10.00	√
	F309	2 <sup>nd</sup> stage-Speed Running Time	0.1 ~ 3000	20.0	√
	F310	2 <sup>nd</sup> stage-Speed Deceleration Time	0.1 ~ 3000	20.0	√
	F311	2 <sup>nd</sup> stage-Speed Stop/Waiting Time	0.0 ~ 3000	0.0	√
	F312	3 <sup>rd</sup> stage-Speed Running Direction	0: Forward 1: Reverse	0	√
	F313	3 <sup>rd</sup> stage-Speed Acceleration Time	0.1 ~ 3000	20.0	√
	F314	3 <sup>rd</sup> stage-Speed Running Frequency	F112 ~ F111	15.00	√
	F315	3 <sup>rd</sup> stage-Speed Running Time	0.1 ~ 3000	20.0	√
	F316	3 <sup>rd</sup> stage-Speed Deceleration Time	0.1 ~ 3000	20.0	√
	F317	3 <sup>rd</sup> stage-Speed Stop/Waiting Time	0.0 ~ 3000	0.0	√
	F318	4 <sup>th</sup> stage-Speed Running Direction	0: Forward 1: Reverse	1	√
	F319	4 <sup>th</sup> stage-Speed Acceleration Time	0.1 ~ 3000	20.0	√
	F320	4 <sup>th</sup> stage-Speed Running Frequency	F112 ~ F111	20.00	√
	F321	4 <sup>th</sup> stage-Speed Running Time	0.1 ~ 3000	20.0	√
	F322	4 <sup>th</sup> stage-Speed Deceleration Time	0.1 ~ 3000	20.0	√
	F323	4 <sup>th</sup> stage-Speed Stop/Waiting Time	0.0 ~ 3000	0.0	√
	F324	5 <sup>th</sup> stage-Speed Running Direction	0: Forward 1: Reverse	0	√
	F325	5 <sup>th</sup> stage-Speed Acceleration Time	0.1 ~ 3000	20.0	√
	F326	5 <sup>th</sup> stage-Speed Running Frequency	F112 ~ F111	25.00	√
	F327	5 <sup>th</sup> stage-Speed Running Time	0.1 ~ 3000	20.0	√
	F328	5 <sup>th</sup> stage-Speed Deceleration Time	0.1 ~ 3000	20.0	√
	F329	5 <sup>th</sup> stage-Speed Stop/Waiting Time	0.0 ~ 3000	0.0	√
	F330	6 <sup>th</sup> stage-Speed Running Direction	0: Forward 1: Reverse	0	√
	F331	6 <sup>th</sup> stage-Speed Acceleration Time	0.1 ~ 3000	20.0	√
	F332	6 <sup>th</sup> stage-Speed Running Frequency	F112 ~ F111	30.00	√
	F333	6 <sup>th</sup> stage-Speed Running Time	0.1 ~ 3000	20.0	√
	F334	6 <sup>th</sup> stage-Speed Deceleration Time	0.1 ~ 3000	20.0	√
	F335	6 <sup>th</sup> stage-Speed Stop/Waiting Time	0.0 ~ 3000	0.0	√



Class	Function Code	Definition	Setting Range	Mfr's Value	Note
Multi-Speed Parameters	F336	7 <sup>th</sup> stage-Speed Running Direction	0: Forward 1: Reverse	0	√
	F337	7 <sup>th</sup> stage-Speed Acceleration Time	0.1 ~ 3000	20.0	√
	F338	7 <sup>th</sup> stage-Speed Running Frequency	F112 ~ F111	35.00	√
	F339	7 <sup>th</sup> stage-Speed Running Time	0.1 ~ 3000	20.0	√
	F340	7 <sup>th</sup> stage-Speed Deceleration Time	0.1 ~ 3000	20.0	√
	F341	7 <sup>th</sup> stage-Speed Stop/Waiting Time	0.0 ~ 3000	0.0	√
	F342	Selection of compound speed control for stage-speeds	0: Not Allowed 1: Allowed	0	√
	F343	Selection of compound speed control mode for stage-speeds	0: Multi-stage Speed Running Frequency + Value set for F344 1: Multi-stage speed Running Frequency + AN2 Channel Analog Values	0	√
	F344	Digital Frequency Setting For Compound Speed Control(Hz)	0.00 ~ 20.00	0.00	√
	F345 ~ F360	Reserved			
Programmable Input/Output Terminal Parameters	F400 ~ F407	Reserved			
	F408	OP1 Terminal Function Definition	0: No function 1: Multi-speed terminal 1 2: Multi-speed terminal 2 3: Multi-speed terminal 3 4: Reset 5: Free stop 6: Reserved 7: External Emergency Stop 8: Acceleration / Deceleration Prohibited 9: Jogging Forward Running JOGF 10: Jogging Reverse Running JOGR 11: Frequency increasing by degrees UP 12: Frequency decreasing by degrees DOWN 13: "FWD" Terminal 14: "REV" Terminal 15: Three-Line type Input Terminal of "X" 16: Switchover of Acceleration / Deceleration time 17: Peripheral equipment Malfunction 18: Coding speed control input 19: Close loop switched to open loop 20: Compound channel speed control switch to single channel speed control 21: Terminal Counting 22: Count Value Reset to Zero 23: Pulse Frequency Input terminal (only valid for OP1)	9	×
	F409	OP2 Terminal Function Definition		1	×
	F410	OP3 Terminal Function Definition		2	×
	F411	OP4 Terminal Function Definition		3	×
	F412	OP5 Terminal Function Definition		7	×
	F413	OP6 Terminal Function Definition		13	×
	F414	OP7 Terminal Function Definition		14	×
	F415	OP8 Terminal Function Definition		4	×

Class	Function Code	Definition	Setting Range	Mfr's Value	Note
Programmable Input/Output Terminal Parameters	F416	Relay Output	0: No function 1: Inverter malfunction protection 2: Over latent frequency 3: Free stop 4: Inverter in operation 5: During DC braking 6: Indicating switchover of Acceleration/Deceleration	1	×
	F417	OUT Terminal Output	7: Reaching the set count value 8: Reaching designated count value 9: Overload early warning signal 11: Indication function when reaching a certain frequency 10: Reserved 12: Reserved 13: Reserved	4	×
	F418	FM Output Function Selection	0: Indicate output frequency value 1: Indicate output current value	0	√
	F419	FM Output Calibration (%)	0 ~ 200	100	√
	F420	IM (FM) Output Range Selection	0: 0 ~ 20mA ( 0 ~ 10V ) 1: 4 ~ 20mA ( 2 ~ 10V )	0	√
	F422	Indication function when reaching a certain frequency	Max(5.00,F112)~F111	5.00	
V/F Control Parameters	F500	Slip Compensation	0.00 ~ 0.08	0.03	×
	F501	V/F Curve Control Mode	0: Beeline 1: Polygonal line 2: Square	0	×
	F502	Torque Promotion ( % )	1 ~ MIN ( 15 , F506 )	5	×
	F503、F504	Reserved			
	F505	User-Defined Frequency Point 1 (Hz)	F112 ~ F507	10.00	×
	F506	User-Defined Voltage Point 1 (%)	F502 ~ MIN(100 , F508)	30	×
	F507	User-Defined Frequency Point 2(Hz)	F505 ~ F118	20.00	×
	F508	User-Defined Voltage Point 2 (%)	F506 ~ MIN(100 , F509)	40	×
	F509	Voltage Corresponding of Turnover Frequency (%)	F508 ~ 100	100	×
	F510	Reserved			
	F511	Auto Voltage Adjusting	0: No adjusting 1: Adjusting	0	×
	F512	Carrier-Wave Frequency Setting (kHz)	1 ~ values set as per inverter model	Subject to inverter's setting value	×

Class	Function Code	Definition	Setting Range	Mfr's Value	Note
V/F Control Parameters	F513	Random Carrier-Wave Selection	0: Not allowed 1:Allowed	1	×
	F514	DC Braking Function Selection	0: Not allowed 1: Braking during start 2: Braking during stop 3: Braking for Start + stop	0	×
	F515	Initial Frequency of DC Braking (Hz)	0.00 ~ 5.00	5.00	√
	F516	DC Braking Current (%)	0 ~ 150	100	√
	F517	Braking Lasting Time During Starting (S)	0.0 ~ 10.0	5.0	√
	F518	Braking Lasting Time During Stopping (S)	0.0 ~ 10.0	5.0	√
	F519	Energy Consumption Brake Ratio (%)	0 ~ 100	50	×
	F520 ~ F524	Reserved			
	F525	Stalling Adjusting Function Selection	0: Not allowed 1:Allowed	0	×
	F526	Stalling Current Adjusting (%)	120 ~ 200	160	×
	F527	Stalling Voltage Adjusting (%)	120 ~ 200	140	×
	F528 ~ F560	Reserved			
	PI Adjusting Parameters	F600	PI Adjusting Function Selection	0: Not allowed 1:Allowed	0
F601		PI Adjusting Channel Selection	0: Digital setting 1: AN1 channel setting 2: AN2 channel setting	0	×
F602		PI Adjustment Digit Provided (V)	0.00 ~ 10.00	5.00	×
F603		PI Adjusting Feedback Channel Selection	0: AN1 channel feedback 1: AN2 channel feedback 2: OP1 pulse channel feedback	0	×
F604		Min Analog Set by PI (V)	0.00 ~ F606	0.00	×
F605		Corresponding Feedback for Min Analog Set by PI (V)	0.00 ~ 10.00	0.00	×
F606		Max Analog Set by PI (V)	F604 ~ 10.00	10.00	×
F607		Corresponding Feedback for Max Analog Set by PI (V)	0.00 ~ 10.00	10.00	×
F608		Proportion Gain	1 ~ 1000	100	√
F609		Integration Time (S)	0.1 ~ 10.0	0.1	√
F610		Sampling Cycle (S)	0.1 ~ 10.0	0.1	√

Class	Function Code	Definition	Setting Range	Mfr's Value	Note
PI Adjusting Parameters	F611	PI Adjusting Accuracy (%)	0 ~ 20	5	√
	F612	PI Adjusting Polarity	0:Negative feedback adjusting 1:Positive feedback adjusting	0	×
	F613 ~ F660	Reserved			
Timing Control & Definable Protection Parameters	F700	Mode selection for Free -Stop	0: Immediate stop 1: stop delay	0	×
	F701	Delay time of Free-Stop and Programmable Output Terminal's Action (S)	0.0 ~ 60.0	0.0	×
	F702	Fan Control Selection (valid only for 18.5 ~ 110KW inverter)	0: Temperature controlled fan running 1: Not temperature controlled fan running	0	×
	F703 ~ F704	Reserved			
	F705	Allowed Auto-Start times	0 ~ 5	3	×
	F706	Interval time of Auto-restart (S)	0.0 ~ 10.0	3.0	×
	F707, F708	Reserved			
	F709	Under-voltage Protection Value (V)	200 ~ 420	Subject to inverter's model	<input type="checkbox"/>
	F710 ~ F714	Reserved			
	F715	Overload Adjusting Gains	0 ~ 1000	Adjusting value	○
	F716	Inverter Overloading Coefficient (%)	150 ~ 180	Adjusting value	○
	F717	Motor Overloading Coefficient (%)	20 ~ 120	Adjusting value	○
	F718, F719	Reserved			
	F720	Third Malfunction Type by Counting DOWN	0: No Trouble 1: Acceleration over-current 2: Deceleration over-current 3: Constant-speed over-current 4: Acceleration over-voltage 5: Deceleration over-voltage 6: Constant-speed over-voltage 7: Undervoltage 9: Inverter overload 10: Motor overload 11: Excess temperature 12: User's password error/serious exterior interference 13: Out-phase 15: Emergency stop 16: Galvanoscopy error 17: Peripheral equipment Malfunction		<input type="checkbox"/>
	F721	Second Malfunction Type by Counting DOWN			
F722	Latest Malfunction type				

Class	Function Code	Definition	Setting Range	Mfr's Value	Note
Timing Control & Stable Protection Parameters	F723	The Last Malfunction Frequency (Hz)			□
	F724	The Last Malfunction Current (A)			□
	F725	The Last Malfunction Voltage (V)			□
	F726 ~ F760	Reserved			
Analog Parameters	F800	Min Analog Input (V)	0.00 ~ MIN(F801, 10.00)	0.00	√
	F801	Max Analog Input (V)	MAX ( 0.00 , F800 ) ~ 10.00	10.00	√
	F802 ~ F806	Reserved			
	F807	Corresponding Frequency for Min Analog (Hz)	F112 ~ F111	0.00	√
	F808	Corresponding Frequency for Max Analog (Hz)	F112 ~ F111	50.00	√
	F809	Max Input Pulse Frequency (Hz)	0 ~ 9999	5000	×
	F810	Corresponding Frequency for Max Input Pulse Frequency (Hz)	0.00 ~ F111	50.00	×
	F811	Filtering Time Constant (S)	1.0 ~ 10.0	3.0	√
	F812 ~ F860	Reserved			
Communication Parameters	F900	485 Communication Interface Function Selection	0: Computer 1:485 communication control enclosure	1	×
	F901	Communication Address	1 ~ 127: Inverter address	1	×
	F902	Odd/even calibration	0: No calibration 1: Odd calibration 2: Even calibration	0	×
	F903	Communication Baud rate (bit)	1: 2400 2: 4800 3: 9600 4: 19200	3	×
	F904	No Parameter Mode(valid for Computer Remote Control)	0: run with parameters 1: run without parameters	1	×
	FF905-F960	Reserved			

Remarks: × means that this function code can only be modified at stop.

√ means that this function code can be modified at stop or during running.

□ means that this function code can only be checked but cannot be modified at stop or during running.

○ means that this function code cannot be initialized when inverter's manufacturer value is restored and can only be modified manually.

### Appendix 3 Selection of Braking Resistor & Braking unit

Built-in braking units are available with some of F1500-G series inverters (some inverters of single-phase and below three-phase 18.5KW). Power terminals of these inverters include terminals "P" and "B". They can then be connected with braking resistors externally. Matching standards for the braking resistors are shown in Table 2 below.

Table 2 Selection of Braking Resistance

Inverter Models	Applicable Motor Power ( KW )	Applicable Braking Resistance
F1500-G0007T3B	0.75	Al Housing 80W/200Ω
F1500-G0015T3B	1.5	Al Housing 80W/150Ω
F1500-G0022T3B	2.2	Al Housing 150W/150Ω
F1500-G0037T3B	3.7	
F1500-G0040T3B	4.0	
F1500-G0055T3B	5.5	Al Housing 250W/120Ω
F1500-G0075T3B	7.5	Al Housing 500W/120Ω
F1500-G0110T3C	11	Al Housing 1KW/90Ω
F1500-G0150T3C	15	Al Housing 1.5KW/80Ω

Built-in braking units are not available with inverters above three-phase 18.5KW. Power terminals of these inverters include terminals “P” and “B”. They need to be connected with braking resistors externally. Terminals “P” ( or “+”) and “N” (or “ - ”) of braking unit are connected with inverter’s terminals “P”and “N”. Terminals “P” and “B” of braking unit are connected with braking resistor. Matching standards are shown in Table 3 below.

**Table 3 Selection of Braking unit**

Inverter Models	Applicable Motor Power ( KW )	Applicable Braking unit Models	Applicable Resistance for Braking unit
F1500-G0110T3C	11	HFBU-DR0102	90Ω /3KW
F1500-G0150T3C	15		
F1500-G0185T3C	18.5	HFBU-DR0103	65Ω /4KW
F1500-G0220T3C	22		
F1500-G0300T3C	30		
F1500-G0370T3C	37	HFBU-DR0201	40Ω /6KW
F1500-G0450T3C	45		
F1500-G0550T3C	55		
F1500-G0750T3C	75	HFBU-DR0301	8Ω /9KW

Note: If braking unit is necessary for inverter (power less than 7.5kw inverter) because of too heavy load, the corresponding type of braking unit is HFBU-DR0101 and braking resistance is 90Ω /1.5KW

07012309