

## F1000-G Series AC Drives(0.4-400KW)



### F1000-G Series AC Drives(0.4-400KW)

F1000-G Series of AC drives is our excellent product of general type. By blocking design, the system function is enriched and the anti-jamming capacity and maneuver-ability is improved too. F1000-G series of AC drives is a kind of high-quality and multifunction general-type AC drives that can meet wide-ranging application.

#### Characteristic

- 16 bytes microprocessor. Optimizing and combining the space voltage vector control and random PWM control.
- Torque promotion function.
- Output frequency is 0.50~400Hz, the highest resolution is 0.01Hz.
- Low-noise and random carrier.
- keypad and terminal jogging speed control function.
- Three-stage speed running by terminal control, Seven-stage speed running by binary coding, definable max seven-stage speed automatic circular running.
- DC braking and stalling adjustment.
- Standard MODBUS port.
- Programmable multi-function output terminals.

F1000-G 0150 T3 C

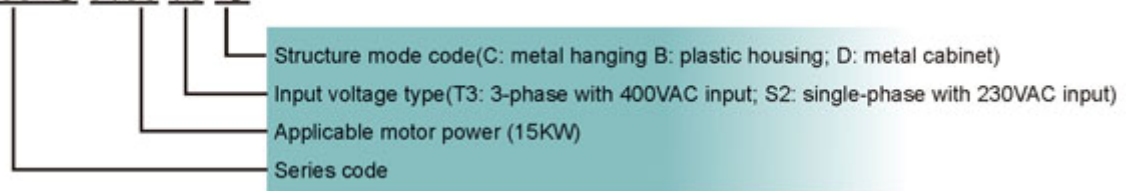

### Technical Specifications

Items		Contents
Input	Rated Voltage Range	3-phase 400V±15%; single-phase 230V±15%
	Rated Frequency	50/60Hz
Output	Rated Voltage Range	3-phase 0~400V; 3-phase 0~230V
	Frequency Range	0.50~400.0Hz
V/F Control	Control Mode	Space voltage vector control and random PWM control
	Frequency Resolution	Max 0.01Hz, adjustment is allowed
	Torque Promotion	Torque promotion curve (V/F) can be random set within 1~16 and definable torque promotion curve is also allowed.
	Stalling Prevention	Current output is restricted and threshold current can be adjusted.
	Overload Capacity	150% rated current, 1minute
Operation Function	Frequency Setting	Potentiometer or external analog signal (0~5V, 0~10V, 0~20mA); keypad (terminal)▲ / ▼ keys, terminal control setting and MODBUS PLC/PC control.
	Start/Stop Control	terminal control, keypad control and MODBUS PLC/PC control.
Protection Function	Input out-phase, input under-voltage, DC over-voltage, over-current, over-load, current stalling, over-heat, external disturbance etc.	
Display	LED nixie tube showing present output frequency, present rotate-speed(rpm), present output current, present output voltage, present linear-velocity, types of faults, and parameters for the system and operation; LED indicators showing the current working status of AC drives.	
Environment Conditions	Equipment Location	Free of tangy caustic gases or dust

	Environment Temperature	-10°C ~ +50°C
	Environment Humidity	Below 90% (no water-bead coagulation)
	Vibration Strength	Below 0.5g (acceleration)
	Height above sea level	1000m or below
Applicable Motor	0.4~400KW	

**Product list/technical Data**

Model	Applicable Motor (kw)	Rated Current Output (A)	Lead Section Area (mm <sup>2</sup> )	Structure Code	Cooling Mode	Remarks
F1000-G0004S2B	0.4	2.5	1.5	B0	Self-cooling	Single-Phase Without built-in braking unit
F1000-G0007S2B	0.75	4.5	2.5	B0	Air Cooling	
F1000-G0015S2B	1.5	7	2.5	B2	Air Cooling	
F1000-G0022S2B	2.2	10	4.0	B3	Air Cooling	
F1000-G0004XS2B	0.4	2.5	1.5	B0	Self-cooling	Single-phase With built-in braking unit
F1000-G0007XS2B	0.75	4.5	2.5	B0	Air Cooling	
F1000-G0015XS2B	1.5	7	2.5	B2	Air Cooling	
F1000-G0007T3B	0.75	2	1.5	B2	Self-cooling	Three-Phase With built-in braking unit
F1000-G0015T3B	1.5	4	2.5	B2	Air Cooling	
F1000-G0022T3B	2.2	6.5	2.5	B2	Air Cooling	
F1000-G0037T3B	3.7	8	2.5	B4	Air Cooling	
F1000-G0040T3B	4.0	9	2.5	B4	Air Cooling	
F1000-G0055T3B	5.5	12	4.0	B5	Air Cooling	

B						Three-Phase Without built-in braking unit
F1000-G0075T3 B	7.5	17	4.0	B5	Air Cooling	
F1000-G0110T3 C	11	23	6.0	C1	Air Cooling	
F1000-G0150T3 C	15	32	10	C2	Air Cooling	
F1000-G0185T3 C	18.5	38	16	C3	Air Cooling	
F1000-G0220T3 C	22	44	16	C3	Air Cooling	
F1000-G0300T3 C	30	60	25	C4	Air Cooling	
F1000-G0370T3 C	37	75	25	C5	Air Cooling	
F1000-G0450T3 C	45	90	35	C5	Air Cooling	
F1000-G0550T3 C	55	110	35	C6	Air Cooling	
F1000-G0750T3 C	75	150	50	C6	Air Cooling	
F1000-G0900T3 C	90	180	70	C7	Air Cooling	
F1000-G1100T3 C	110	220	70	C7	Air Cooling	
F1000-G1320T3 C	132	265	95	C8	Air Cooling	
F1000-G1600T3 C	160	320	120	C8	Air Cooling	
F1000-G1800T3 C	180	360	150	C9	Air Cooling	
F1000-G2000T3 C	200	400	150	CA	Air Cooling	
F1000-G2200T3 C	220	440	185	CA	Air Cooling	
F1000-G1100T3 D	110	220	70	D0	Air Cooling	
F1000-G1320T3 D	132	265	95	D1	Air Cooling	
F1000-G1600T3 D	160	320	120	D1	Air Cooling	
F1000-G1800T3 D	180	360	150	D1	Air Cooling	

D					
F1000-G2000T3 D	200	400	150	D2	Air Cooling
F1000-G2200T3 D	220	440	185	D2	Air Cooling
F1000-G2500T3 D	250	480	240	D3	Air Cooling
F1000-G2800T3 D	280	520	240	D3	Air Cooling
F1000-G3150T3 D	315	550	300	D3	Air Cooling
F1000-G3550T3 D	355	595	300	D3	Air Cooling
F1000-G4000T3 D	400	650	400	D4	Air Cooling

**Basic Wiring Diagram**

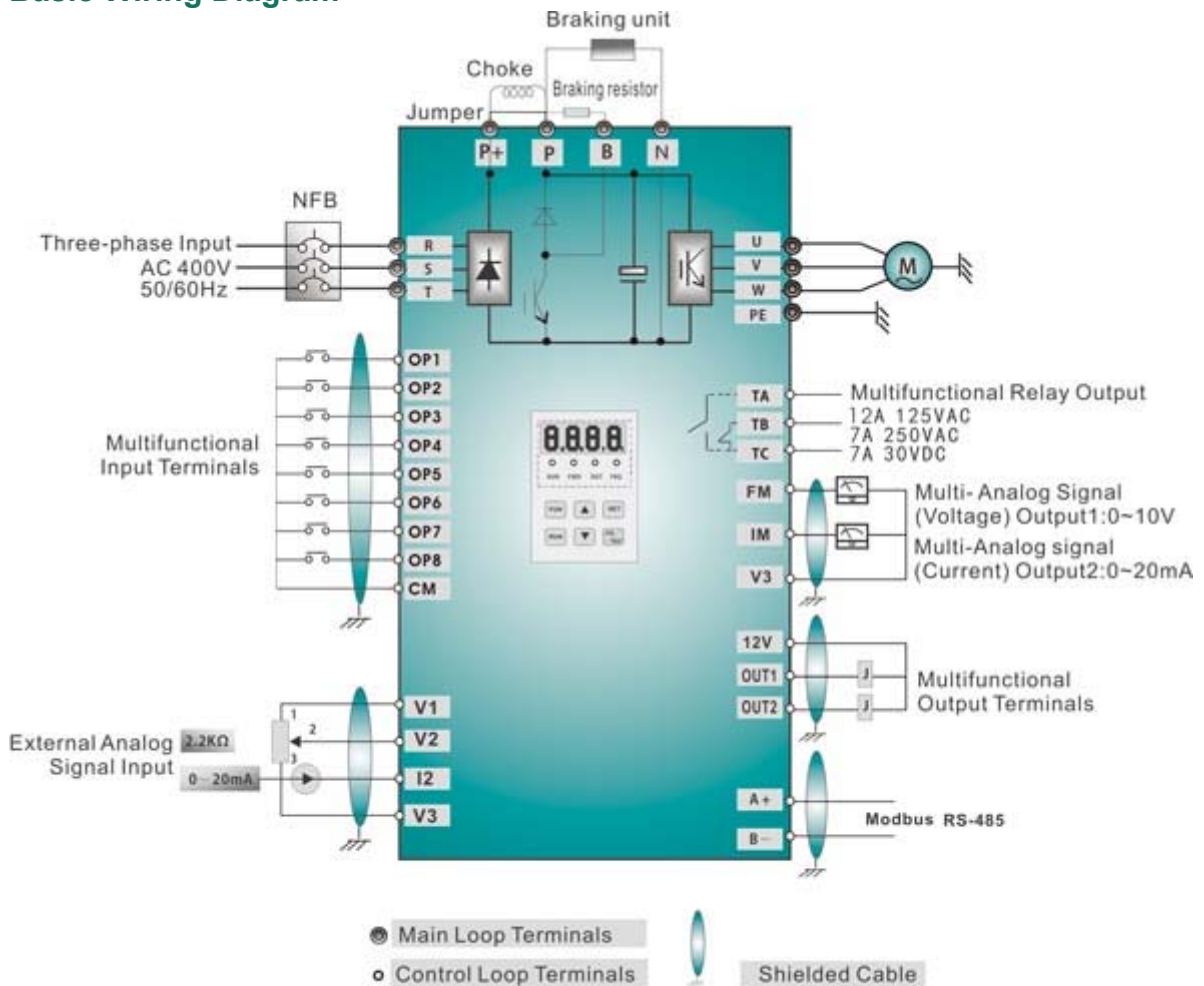

**Basic Wiring Diagram for Three-phase AC drives (NPN type)**