

INVERTER

SPEECON

7200GS/GS510

220V Class 3 Φ 25~100HP

440V Class 3 Φ 25~500HP

Please hand this manual to the end-users. It will be of great help for their daily operation, maintenance, inspection and troubleshooting.

BEFORE INSTALLATION & USE

1. Ensure nameplate data corresponds with your requirements.
2. Ensure the apparatus is undamaged.

WARNING

The following safety precautions must be observed:

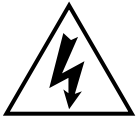

1. Electric apparatus and electricity can cause serious or fatal injury if the apparatus is improperly installed, operated or maintained. Responsible personnel must be fully trained to understand the hazards to themselves and others before being involved in installing, operating, maintaining and decommissioning electrical apparatus. European Union Safety information can be obtained from such as:

BS4999; EN60204-1 EN292-1 EN294
IEE Wiring Regulations

Particular industries and countries have further safety requirements. Refer to their trade safety bodies, British Standards Institution, Dept. of Trade & Industry, etc., for further information. For instance, in the USA, refer to NEMA MG2, the National Electrical Code, local safety requirements, etc.

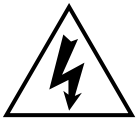

2. When servicing, all power sources to the apparatus and to the accessory devices should be de-energized and disconnected and all moving parts at standstill.
3. Safety guards and other protective, devices must neither be bypassed nor rendered inoperative.



4. The apparatus must be earthed. Refer to relevant standards such as EN60204-1, IEE Wiring Regulation etc.
5. A suitable enclosure must be provided to prevent access to live parts. Extra caution should be observed around apparatus that is automatically started or has automatic resetting relays or is remotely started in case such starting means has not been properly disabled and the apparatus starts unexpectedly.

CAUTION AND WARNING:

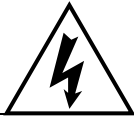

WARNING

- Do not change the wiring while power is applied to the circuit.
- After turning OFF the main circuit supply, do not touch circuit components until CHARGE LED is extinguished.
- Never connect power circuit output U (T1), V (T2), W (T3) to AC power supply.
- When the retry function (Cn-36) is selected, motor may restart suddenly after being stopped by momentary power loss.



CAUTION

- When mounting units in a separate enclosure, install a fan or other cooling device to keep the intake air temperature below 45°C.
- Do not perform a withstand voltage test to the inverter.
- All the constants of the inverter have been factory preset. Do not change the settings unnecessarily.

CONTENTS

1. WIRING	4
1.1 NOTES ON WIRING TO PERIPHERAL UNITS	4
1.2 CONNECTION DIAGRAM.....	5
1.3 TERMINAL FUNCTION.....	6
1.3.1 MAIN CIRCUIT TERMINALS	6
1.3.2 CONTROL CIRCUIT TERMINALS	6
1.3.3 MAIN CIRCUIT SCHEMATIC	7
1.4 WIRING PARTS.....	8
1.4.1 RECOMMENDED WIRING PARTS	8
1.4.2 CAUTIONS FOR WIRING	10
1.4.3 FUSE TYPE.....	12
1.5 SPECIFICATIONS.....	13
1.6 DIMENSIONS	15
2. DESCRIPTION OF USING 7200GS/GS510.....	17
2.1 Using LCD (OR LED) digital operator	17
2.2 DRIVE mode and PRGM mode displayed contents	19
2.3 Parameter description	20
2.4 Sample example of using LCD digital operator.....	21
3. SETTING USER CONSTANT	23
3.1 Frequency Command An-□□	23
3.2 Parameters Can Be Changed during Running Bn-□□	24
3.3 Control Parameters Cn-□□.....	26
3.4 System Parameters Sn-□□.....	29
3.5 Monitoring Parameters Un-□□.....	35
3.6 Monitoring Parameters Hn-□□.....	38
3.7 Order Parameters On-□□	40
4. FAULT DISPLAY AND TROUBLE SHOOTING.....	42

1. WIRING

1.1 NOTES ON WIRING TO PERIPHERAL UNITS

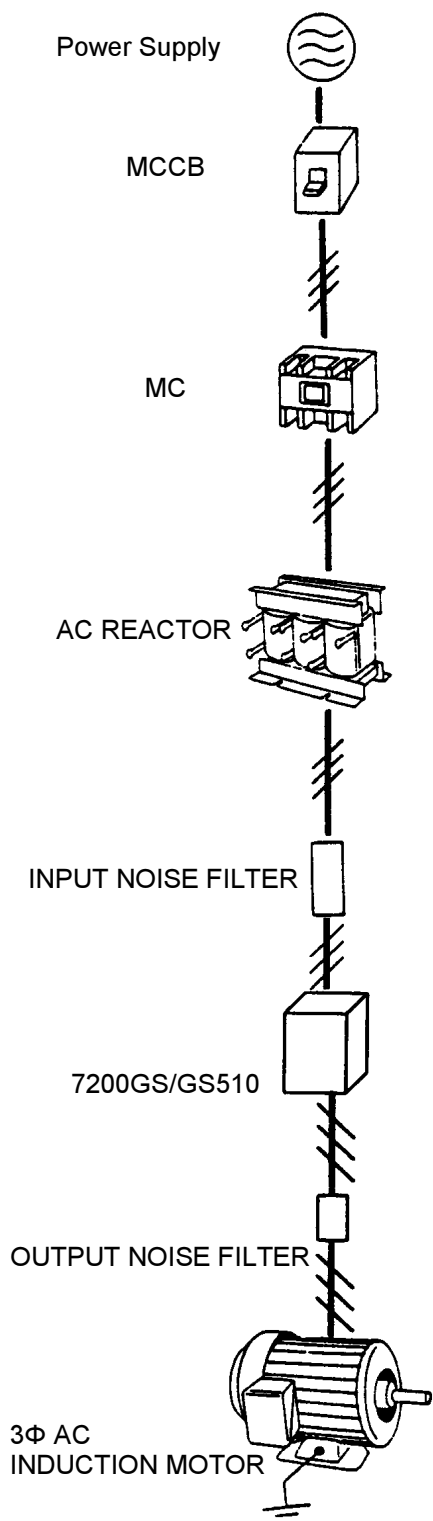

- **MCCB (molded case circuit breaker)**
Please refer to Table 1. for MCCB selection.
Do not use a circuit breaker for start/stop operation.
When a ground fault interrupter is used, select the one with no influence for high frequency. Setting current should be 200mA or above and the operating time at 0.1 second or longer to prevent malfunction.
- **MC (magnetic contactor)**
It is not always necessary to have the MC on the input side. However, an input MC can be used to prevent an automatic restart after recovery from an external power loss during remote control operation.
Do not use the MC for start/stop operation.
- **AC REACTOR**
To improve power factor or to reduce surge, install an AC reactor. There is a DC choke built-in on 7200GS/GS510, models 25HP(18.5 KW) and larger for 220V class and 30HP(22 KW) and larger for 440V class. The 440V 300 ~ 400HP need to install AC reactor externally.
- **Input Noise Filter**
When used with specified input noise filter, the 7200GS/GS510 can comply with EN55011 class A. Please refer to our EMC technical manual for noise filter selection.
- **Inverter**
Wire input to terminals L1, L2 and L3 for three phase input. Make sure to connect the ground terminal to an appropriate safety ground.
- **Output Noise Filter (EMI Suppression zero core)**
When used with output noise filter, radiated and conducted emissions may be reduced.
- **Motor**
When multiple motors are driven in parallel with an inverter, the inverter rated current should be at least 1.1 times the total motor rated current. Make sure that the motor and the inverters are separately grounded.

1.2 CONNECTION DIAGRAM

The following diagram shows interconnection of the main circuit and control circuit. With the digital operator, the motor can be operated by wiring the main circuit only. (Terminal Symbols: ⊕ indicates main circuit; ○ indicates control circuit).

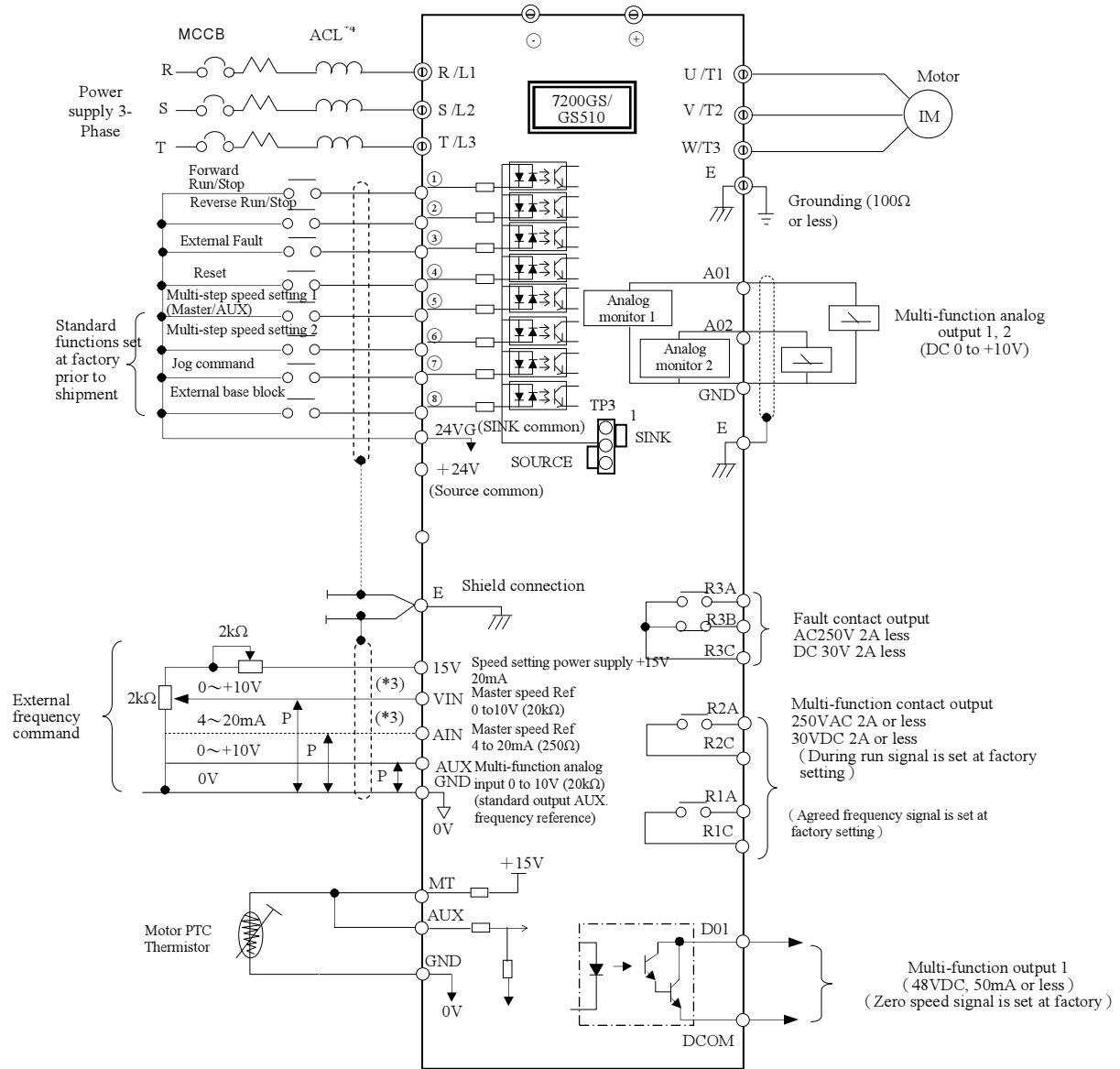

Fig. 2 Standard connection diagram.

【*1】 shield wire shield twisted wire

【*2】 The terminal ⊕ ~ ⊗ can be connected as SINK or SOURCE type input interface which depends on the status of “TP3”. Plug in the jumper at the TP3 SINK side when using the SINK type interface, SOURCE side when SOURCE type interface was used.

【*3】 The terminal arrangement

1	2	3	4	5	6	7	8	9	10	11	12	13	14	15	16	17	18	19	20	21	22	23	24	1	2	3	4	5	6	7
24VG	1	2	3	4	5	6	7	8	24V	S+	S-	E	15V	VIN	AIN	AUX	MT	GND	A01	A02	GND	DCOM	D01	R1A	R1C	R2A	R2C	R3A	R3B	R3C

【*4】 440V 350HP~500HP need to install ACL externally.

1.3 TERMINAL FUNCTION

1.3.1 MAIN CIRCUIT TERMINALS

Table 1. Main Circuit Terminals

HP Range Terminals	440V: 25HP	220V: 25~100HP 440V: 30~400HP
R / L1	Main Circuit Input Power Supply	
S / L2		
T / L3		
U / T1	Inverter Output	
V / T2		
W / T3		
B1/P	<ul style="list-style-type: none"> ● B1/P - B2: Braking Resistor ● B1/P - ⊖: DC power supply 	—
B2		
⊖	—	<ul style="list-style-type: none"> ● ⊕~⊖: DC Power Supply or Braking Unit
⊕		
E (PE, \perp)	Grounding (3rd Type Grounding)	

1.3.2 CONTROL CIRCUIT TERMINALS

Table 2. Control Circuit Terminals

I/O	Terminal	Functions	
Digital Input Terminals	1	Forward operation-stop signal.	
	2	Reverse operation-stop signal.	
	3	External fault input.	
	4	Fault reset.	
	5	Multi-function contact input: the following signals are available to select: Forward/reverse select, mode select, multi-speed select, jog frequency select, accel/decel time select external fault, external coast to stop, hold command, AC Drive overheat prediction, DB command, aux. Input effective, speed search, and energy-saving operation.	
	6		
	7		
	8		
		24VG	SINK Common, ref to TP3 jumper status.
		24V	SOURCE Common, ref to TP3 jumper status.
	E	Connection to shield signal lead. (frame ground)	
Analog Input Terminals	15V	+15V power supply for external frequency command.	
	VIN	Master speed voltage reference (0 to 10V).	
	AIN	Master speed current reference (4 to 20mA).	
	AUX	Auxiliary analog command: one of the following signals available to select. Frequency command, frequency gain, frequency bias, over torque detection level, voltage bias, accel/decel rate, DB current.	
	MT	Motor temperature PTC thermistor. (active: 1330Ω, Return: 550Ω)	
	GND	Analog signal common.	
		E	Connection to shield signal lead. (frame ground)
Digital Output Terminals	R3A	Fault contact output A (Closed at fault)	
	R3B	Fault contact output B (Open at fault)	
	R3C	Fault contact output common.	
	R2A	Multi-function contact output: one of the following signals available to output. Output during running, zero speed, synchronized speed, arbitrary speed agreed, frequency detection, over torque, under voltage, run mode, coast to stop, braking resistor overheat alarm, fault.	
	R2C		
	R1A		
	R1C		
		D01	Multi-function PHC (photo-coupler) output 1 (open collector, 48VDC, 50mA)
	DCOM	Multi-function PHC output common.	
Analog Output Terminals	A01	Analog multifunction output port: Frequency command, Output frequency, Output current, Output voltage, DC voltage, Output power.	0~11V max. 2mA or less
	A02		
	GND	Common lead for analog port.	
RS-485	S+	RS-485 communication port	
	S-		

1.3.3 MAIN CIRCUIT SCHEMATIC

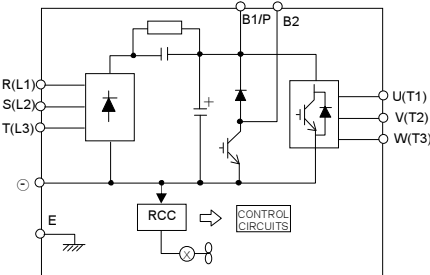
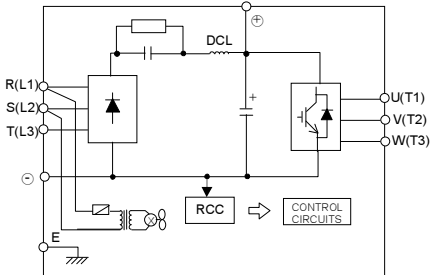
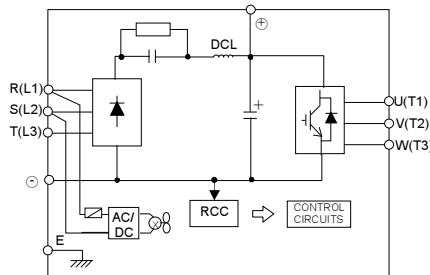
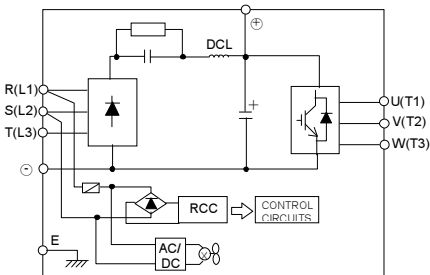
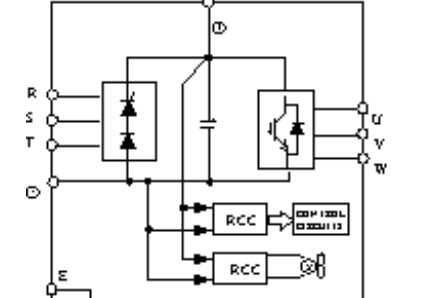
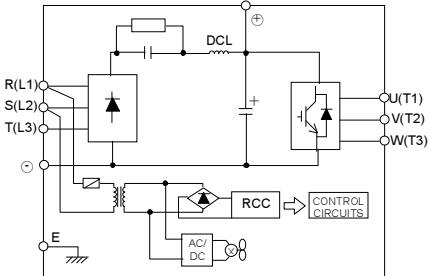
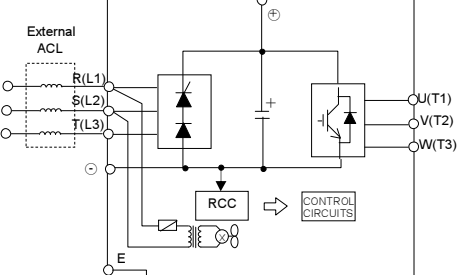
<p>1. 440V : 25HP</p> 	<p>2. 220V : 25HP 440V : 30HP, 40HP, 50HP</p> 
<p>3. 220V : 30HP, 40HP 440V : 60HP, 75HP</p> 	<p>4. 220V : 50HP, 60HP, 75HP, 100HP</p> 
<p>5. 440V : 100HP</p> 	<p>6. 440V : 125HP, 150HP, 175HP, 215HP, 250HP</p> 
<p>7. 440V : 300HP, 400HP, 500HP</p>  <p>* External ACL is necessary</p>	

1.4 WIRING PARTS

1.4.1 RECOMMENDED WIRING PARTS

Be sure to connect MCCBs between power supply and 7200GS/GS510 input terminals L1 (R), L2 (S), L3 (T). Recommended MCCBs are listed in Table 3.

When a ground fault interrupter is used, select the one with no influence for high frequency. The current setting should be 200mA or over and operating time, 0.1 second or over to prevent malfunction.

Table 3. 220V and 440V class applicable wire size and contactor

(a) 220V SERIES

Max. Applicable Motor Output HP (KW) [Note 1]	Cable Size - mm ² (AWG)			Molded-Case Circuit Breaker [Note 4]	Magnetic Contactor [Note 4]
	Power Cable [Note 2]	Ground Cable E [G]	Control Cable [Note 3]		
25(18.5)	22 (4)	14 (6)	0.5~2 (20-14)	TO-225S (150A)	CN-80
30(22)	30 (2)	14 (6)	0.5~2 (20-14)	TO-225S (175A)	CN-100
40(30)	60 (2/0)	22 (4)	0.5~2 (20-14)	TO-225S (175A)	CN-125
50(37)	60×2P (2/0)	22 (4)	0.5~2 (20-14)	TO-225S (200A)	CN-150
60(45)	60×2P (2/0×2P)	22 (4)	0.5~2 (20-14)	TO-225S (225A)	CN-180
75(55)	60×2P (2/0×2P)	30 (2)	0.5~2 (20-14)	TO-400S (300A)	CN-300
100(75)	100×2P (4/0×2P)	50 (1/0)	0.5~2 (20-14)	TO-400S (400A)	CN-300

[Note] 1. For Constant Torque Load.

2. Power Cable Include Cables to the Terminals R (L1), S (L2), T (L3), ⊕ , ⊖ , BR, U (T1), V (T2), W (T3).
3. Control Cable Include Cables to the Control Terminals.
4. The Molded-Case Circuit Breaker and Magnetic Contactors Shown in Table are TECO Products and are for reference only. Other manufactures' equivalent products may be selected.
5. The Magnetic contactors S-K400 and S-K600 are Mitsubishi Products and are for reference only. Other manufactures' equivalent products may be selected.

(b) 440V SERIES

Max. Applicable Motor Output HP (KW) [Note 1]	Cable Size - mm ² (AWG)			Molded-Case Circuit Breaker [Note 4]	Magnetic Contactor [Note 4]
	Power Cable [Note 2]	Ground Cable E [G]	Control Cable [Note 3]		
25(18.5)	8 (8)	8 (8)	0.5~2 (20-14)	TO-100S (75A)	CN-50
30(22)	14 (6)	8 (8)	0.5~2 (20-14)	TO-100S (100A)	CN-50
40(30)	22 (4)	8 (8)	0.5~2 (20-14)	TO-100S (100A)	CN-65
50(37)	22 (4)	14 (6)	0.5~2 (20-14)	TO-125S (125A)	CN-80
60(45)	38 (1)	14 (6)	0.5~2 (20-14)	TO-225S (175A)	CN-100
75(55)	60 (2/0)	22 (4)	0.5~2 (20-14)	TO-225S (175A)	CN-125
100(75)	60×2P (2/0)	22 (4)	0.5~2 (20-14)	TO-225S (225A)	CN-150
125(90)	60×2P (2/0×2P)	30 (2)	0.5~2 (20-14)	TO-400S (300A)	CN-300
150(110)	60×2P (2/0×2P)	30 (2)	0.5~2 (20-14)	TO-400S (300A)	CN-300
175(132)	100×2P (4/0×2P)	50 (1/0)	0.5~2 (20-14)	TO-400S (400A)	CN-300
215(160)	100×2P (4/0×2P)	50 (1/0)	0.5~2 (20-14)	TO-400S (400A)	CN-300
250(185)	250×2P (2P)	50 (1/0)	0.5~2 (20-14)	TO-600S (600A)	S-K400 [Note 5] (450A)
300(220)	250×2P (2P)	60 (2/0)	0.5~2 (20-14)	TO-800S (800A)	S-K600 (800A)
400(300)	250×2P (2P)	60 (2/0)	0.5~2 (20-14)	TE-1000 (1000A)	S-K600 (800A)
500(375)	250×2P (2P)	60 (2/0)	0.5~2 (20-14)	TE-1000 (1000A)	S-K800 (1000A)

1.4.2 CAUTIONS FOR WIRING

	CAUTION
<p>The external interconnection wiring must be performed with the following procedures.</p> <p>After completing 7200GS/GS510 interconnections, be sure to check that connections are correct. Never use control circuit buzzer check.</p>	

(A) MAIN CIRCUIT INPUT/OUTPUT

- (1) Phase rotation of input terminals L1 (R), L2 (S), L3 (T) is available in either direction. (Clockwise and counterclockwise).
- (2) When inverter output terminals T1 (U), T2 (V), and T3 (W) are connected to motor terminals T1 (U), T2 (V), and T3 (W), respectively, motor rotates counterclockwise. (Viewed from opposite side of drive end, upon forward operation command). To reverse the rotation interchange any two of the motor leads.
- (3) Never connect AC main circuit power supply to output terminals T1 (U), T2 (V), and T3 (W). This may cause damage to the inverter.
- (4) Care should be taken to prevent contact of wiring leads with 7200GS/GS510 cabinet. If this occurs, a short-circuit may result.
- (5) Never connect power factor correction capacitors or noise filters to 7200GS/GS510 output.
- (6) Never open or close contactors in the output circuit unless inverter is properly sized.

	CAUTION
<ul style="list-style-type: none">● Lead size should be determined taking into account voltage drop of leads. Voltage drop can be obtained by the following equation: select such lead size that voltage drop will be within 2% of normal rated voltage. phase-to-phase voltage drop (V) $= \sqrt{3} \times \text{lead resistance (}\Omega/\text{km)} \times \text{wiring distance(m)} \times \text{current(A)} \times 10^{-3}$.● Wiring length between inverter and motor. If total wiring distance between inverter and motor is excessively long and inverter carrier frequency (main transistor switching frequency) is high, harmonic leakage current from the cable will increase to effect the inverter unit or peripheral devices. If the wiring distance between inverter and motor is long, reduce the inverter carrier frequency.	

(B) GROUNDING (PE: Protective Earth)

Ground the 7200GS/GS510 through ground terminal E (PE).

- (1) Ground resistance should be 100 ohms or less.
- (2) Never ground 7200GS/GS510 in common with welding machines, motors, and other large-current electrical equipment, or ground pole. Run the ground lead in separate conduit from leads for large-current electrical equipment.
- (3) Use the ground leads which comply with AWG standards and make the sure the length is as short as possible.
- (4) Where several 7200GS/GS510 units are used side by side, it is preferable to ground each unit separately to ground poles. However, connecting all the ground terminals of 7200GS/GS510 in parallel while grounding only one of the 7200GS/GS510's to the ground pole is also permissible (Fig. 3). Be sure not to form a loop with the ground leads.

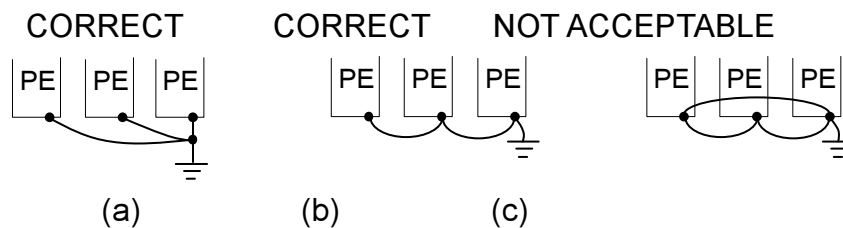

Fig. 3 Grounding of Three 7200GS/GS510 Units

(C) CONTROL CIRCUIT

- (1) Separation of control circuit leads and main circuit leads: All signal leads must be separated from main circuit leads L1 (R), L2 (S), L3 (T), ⊕, ⊖, B2, T1 (U), T2 (V), T3 (W) and other power cables to prevent erroneous operation caused by noise interference.
- (2) Control circuit leads ⑨, ⑩, ⑱, ⑲, ⑳ (contact output) must be separated from leads 1 to 8, ㉑, ㉒, ㉓, ㉔, ㉕ and ⑪~⑰.
- (3) Use twisted shielded or twisted pair shielded wire for the control circuit line and connect the shield sheath to the inverter terminal E to prevent malfunction caused by noise. See Fig.4. Wiring distance should be less than 164ft (50m).

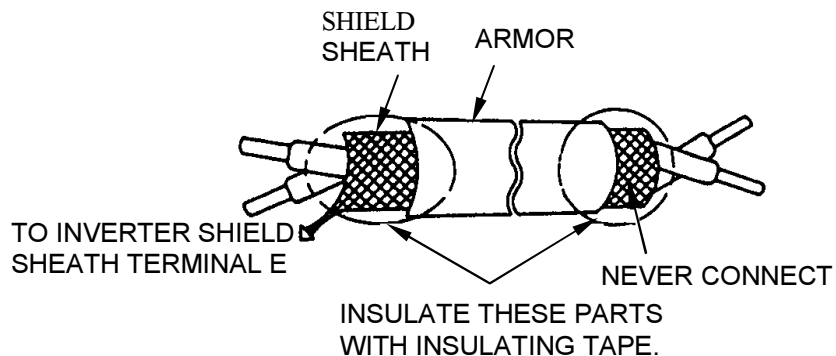

Fig. 4 Shielded Wire Termination

1.4.3 Fuse types

Drive input fuses are provided to disconnect the drive from power in the event that a component fails in the drive's power circuitry. The drive's electronic protection circuitry is designed to clear drive output short circuits and ground faults without blowing the drive input fuses. Below table shows the 7200GS/GS510 input fuse ratings.

To protect the inverter most effectively, use fuses with current-limit function.

220V class

MODEL	HP	KVA	100% CONT. Output AMPS	Rated Input AMPS	FUSE Rating
JNTEBG□□7R50JK	7.5	10.3	24	29	50
JNTEBG□□0010JK	10	13.7	32	38	60
JNTEBG□□0015JK	15	20.6	48	58	100
JNTEBG□□0020JK	20	27.4	64	77	125
JNTEBG□□0025JK	25	34	80	88	125
JNTEBG□□0030JK	30	41	96	106	150
JNTEBG□□0040JK	40	54	130	143	200
JNTEBG□□0050JK	50	57	160	176	250
JNTEBG□□0060JK	60	67	183	201	300
JNTEBG□□0075JK	75	85	224	246	350
JNTEBG□□0100JK	100	128	300	330	450

440V class

MODEL	HP	KVA	100% CONT. Output AMPS	Rated Input AMPS	FUSE Rating
JNTEBG□□7R50AZ	7.5	10.3	12	14	25
JNTEBG□□0010AZ	10	13.7	16	19	30
JNTEBG□□0015AZ	15	20.6	24	29	50
JNTEBG□□0020AZ	20	27.4	32	38	60
JNTEBG□□0025AZ	25	34	40	48	70
JNTEBG□□0030AZ	30	41	48	53	80
JNTEBG□□0040AZ	40	54	64	70	100
JNTEBG□□0050AZ	50	68	80	88	125
JNTEBG□□0060AZ	60	82	96	106	150
JNTEBG□□0075AZ	75	110	128	141	200
JNTEBG□□0100AZ	100	138	165	182	250
JNTEBG□□0125AZ	125	180	192	211	300
JNTEBG□□0150AZ	150	195	224	246	350
JNTEBG□□0175AZ	175	230	270	297	400
JNTEBG□□0215AZ	215	260	300	330	450
JNTEBG□□0250AZ	250	290	340	374	500
JNTEBG□□0300AZ	300	385	450	540	700
JNTEBG□□0400AZ	400	513	600	720	900
JNTEBG□□0500AZ	500	561	660	805	1000

Fuse Type UL designated SEMICONDUCTOR PROTECTION FUSES

Class CC, J, T, RK1 or RK5

Voltage Range: 300V for drives with 220V class VFD

600V for drives with 440V class VFD

1.5 SPECIFICATIONS

● Basic Specifications

220V CLASS

INVERTER (HP)		25	30	40	50	60	75	100
MAX. APPLICABLE MOTOR OUTPUT HP (KW)*1		25 (18.5)	30 (22)	40 (30)	50 (37)	60 (45)	75 (55)	100 (75)
Output Characteristics	Inverter Capacity (KVA)	34	41	54	57	67	85	128
	Rated Output Current (A)	80	96	130	160	183	224	300
	Max. Output Frequency	3-Phase, 200/208/220/230V (Proportional to input voltage)						
	Rated Output Frequency	Up to 400Hz available						
Power Supply	Rated Input Voltage And Frequency	3-Phase, 200/208/220V, 50Hz 200/208/220/230V, 60Hz						
	Allowable Voltage Fluctuation	+10% ~ -15%						
	Allowable Frequency Fluctuation	±5%						

7200GS 440V CLASS

INVERTER (HP)		25	30	40	50	60	75	100	125	150	175	215	250	300	400	500
MAX. APPLICABLE MOTOR OUTPUT HP (KW)*1		25 (18.5)	30 (22)	40 (30)	50 (37)	60 (45)	75 (55)	100 (75)	125 (90)	150 (110)	175 (132)	215 (160)	250 (185)	300 (220)	400 (300)	500 (375)
Output Characteristics	Inverter Capacity (KVA)	34	41	54	68	82	110	138	180	195	230	260	290	385	513	561
	Rated Output Current (A)	40	48	64	80	96	128	165	192	224	270	300	340	450	600	660
	Max. Output Frequency	3-Phase, 380/400/415/440/460V (Proportional to input voltage)														
	Rated Output Frequency	Up to 400Hz available														
Power Supply	Rated Input Voltage And Frequency	3-Phase, 380/400/415/440/460V, 50/60Hz														
	Allowable Voltage Fluctuation	+10% ~ -15%														
	Allowable Frequency Fluctuation	±5%														

*1 Based on 4 pole motor

GS510 440V CLASS

INVERTER (HP)		25	30	40	50	60	75	100	125	150	175	215	250
MAX. APPLICABLE MOTOR OUTPUT HP (KW)*1		25 (18.5)	30 (22)	40 (30)	50 (37)	60 (45)	75 (55)	100 (75)	125 (90)	150 (110)	175 (132)	215 (160)	250 (185)
Output Characteristics	Inverter Capacity (KVA)	34	41	54	68	82	110	138	180	195	230	260	290
	Rated Output Current (A)	38	44	59	75	86	111	151	189	231	267	300	340
	Max. Output Frequency	3-Phase, 380/400/415/440/460V (Proportional to input voltage)											
	Rated Output Frequency	Up to 400Hz available											
Power Supply	Rated Input Voltage And Frequency	3-Phase, 380/400/415/440/460V, 50/60Hz											
	Allowable Voltage Fluctuation	+10% ~ -15%											
	Allowable Frequency Fluctuation	±5%											

*1 Based on 4 pole motor

CHARACTERISTICS

Control Characteristics	Control Method	<ul style="list-style-type: none"> ● Sine wave PWM ● V/F control
	Starting Torque	● V/F control: 150% at 3Hz
	Speed Control Range	● V/F control: 1 : 10
	Speed Control Accuracy	● V/F control: ±1% (with slip compensation)
	Frequency Control Range	0.1 ~ 400.0Hz
	Frequency Setting Resolution	Digital reference: 0.01Hz (100Hz Below); Analog reference: 0.06Hz/60Hz
	Frequency Accuracy	Digital reference: ±0.01% (-10 ~ +40°C); Analog command: ±0.1% (25°C ± 10°C)
	Output Frequency Resolution	0.01Hz (1/30000)
	Frequency Setting Signal	0 ~ 10VDC (20KΩ), 4~20mA (250Ω)
	Overload Capacity	150% rated output current for 1 minute.
	Accel/Decel Time	0.1 ~ 6000.0 sec (Accel/Decel time settings independently)
	Efficiency at Rated Freq.	0.95 above
Braking Torque	Approx. 20% (Approx. 125% When using braking resistor) Inverter of 220V 20HP (15KW) or less and 440V 25HP (18.5KW) or less have a Built-in braking transistor	
Protective Functions	Motor Overload Protection	Electric thermal overload relay
	Instantaneous Overcurrent (OC) and Short Circuit Protection	Motor coasts to stop at approx. 200% rated output current.
	Inverter Overheat Protection (OL2)	150% inverter rated output current for 1 min.
	Overvoltage (OV)	Motor coasts to stop if the main circuit voltage exceeds 410VDC (820VDC for 440V class)
	Undervoltage (UV)	Motor coasts to stop if the main circuit voltage drops to 190VDC (380VDC for 440V class)
	Momentary Power Loss	Immediately stop after 15 ms or longer power loss (at factory setting) Continuous operation during power loss less than 2 sec. (standard)
	Fin Overheat (OH)	Thermostat
	Stall Prevention	Stall prevention during acceleration/deceleration and constant speed operation.
	Ground Fault (GF)	Provided by electronic circuit.
	Power Charge Indication	Indicates until main circuit voltage reaches 50V.
Environmental Conditions	Location	Indoor (Protected from corrosive gases and dust)
	Humidity	95% RH (non-condensing)
	Storage Temperature	-20 ~ +60°C (for short period during shipping)
	Ambient Temperature	-10 to +40°C (for NEMA1 type); -10 to +45°C (for open chassis type)
	Altitude	1000m or below
	Vibration	9.8m/s ² at 20Hz or below, up to 2m/s ² at 20 to 50Hz
Communication Function	MODBUS Installed, PROFIBUS (option)	
EMI	Meet EN 50081-2 (1994) with specified EMI filter	
EMC Compatibility	Meet Pr EN50082-2	

1.6 DIMENSIONS

Table 7 7200GS Dimension and Weight

Voltage (V)	Inverter Capacity (HP)	Open Chassis Type (IP00) mm						Weight (Kg)	Enclosed Type (NEMA1) mm						Weight (Kg)	ACL/DCL	Reference Figure
		W	H	D	W1	H1	d		W	H	D	W1	H1	d			
220V	25	283.5	525	307	220	505	M8	30	291.5	745	307	220	505	M8	33	DCL Built-in (Standard)	(b)
	30							33									
	40	459	790	324.6	320	760	M10	75	462	1105	324.6	320	760	M10	81		
	50							76							82		
	60							79							85		
	75							79							88		
	100	599	1000	381.6	460	960	M12	120	602	1305	381.6	460	960	M12	130		
440V	25	265	360	225	245	340	M6	12	265	360	225	245	340	M6	12	External ACL (option)	(a)
	30	283.5	525	307	220	505	M8	36	291.5	745	307	220	505	M8	38	DCL Built-in (Standard)	(b)
	40							36							38		
	50	344	630	324.5	250	610	M8	47	352	945	324.5	250	610	M8	50		
	60							47							50		
	75							47							50		
	100							62							65		
	125	459	790	324.6	320	760	M10	80	462	1105	324.6	320	760	M10	85		
	150							81							86		
	175							81							86		
	215	599	1000	381.6	460	960	M12	132	602	1305	381.6	460	960	M12	139		
	250							132							139		
	300	730	1230	382	690	930	M12	170	730	1330	382	690	930	M12	176		
	400							190							196		
500	190							196									

GS510 Dimension and Weight

Voltage (V)	Inverter Capacity (HP)	Open Chassis Type (IP00) mm						Weight (Kg)	Enclosed Type (NEMA1) mm						Weight (Kg)	ACL/DCL	Reference Figure
		W	H	D	W1	H1	d		W	H	D	W1	H1	d			
440V	25	265	360	225	245	340	M6	12	265	360	225	245	340	M6	12	External ACL (option)	(a)
	30																
	40	283.5	525	307	220	505	M8	36	291.5	745	307	220	505	M8	38	DCL Built-in (Standard)	(b)
	50																
	60	344	630	324.5	250	610	M8	47	352	945	324.5	250	610	M8	50	DCL Built-in (Standard)	
	70																
	100																
	125	459	790	324.6	320	760	M10	80	462	1105	324.6	320	760	M10	85	DCL Built-in (Standard)	
	150																
	175																
	215	599	1000	381.6	460	960	M12	132	602	1305	381.6	460	960	M12	139	DCL Built-in (Standard)	
	250																

(a) 440V : 25HP

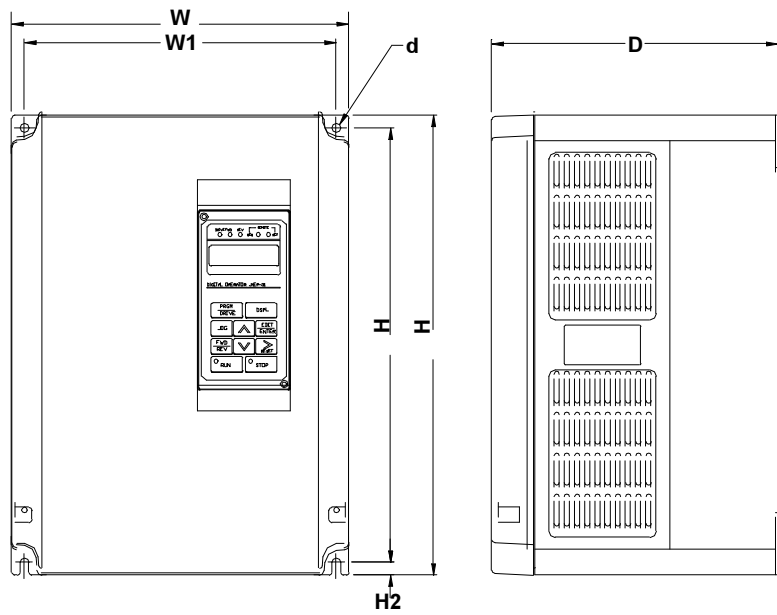

(b) 220V : 25HP ~ 100HP
 440V : 30HP ~ 250HP

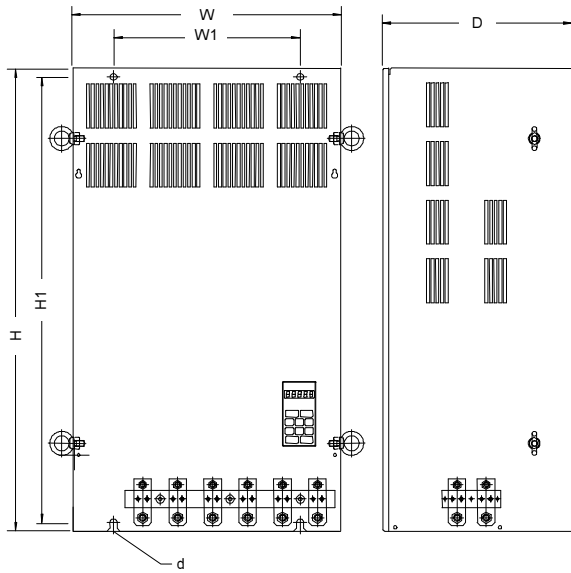

(Open Chassis Type – IP00)

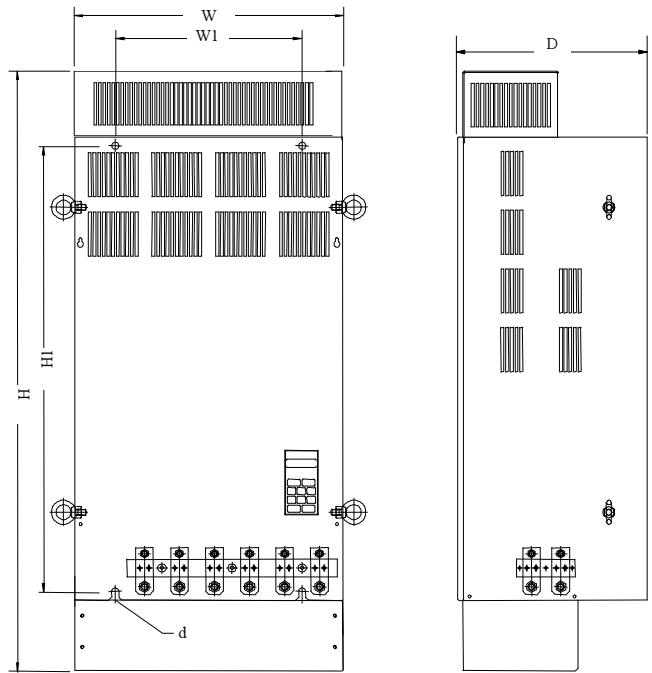

(Wall-mounted Type – NEMA1)

(d) 440V : 300HP, 400HP, 500HP

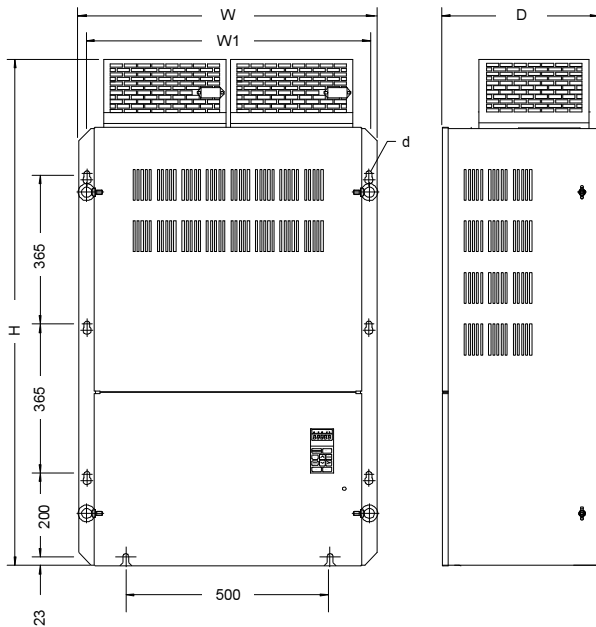

(Open Chassis Type – IP00)

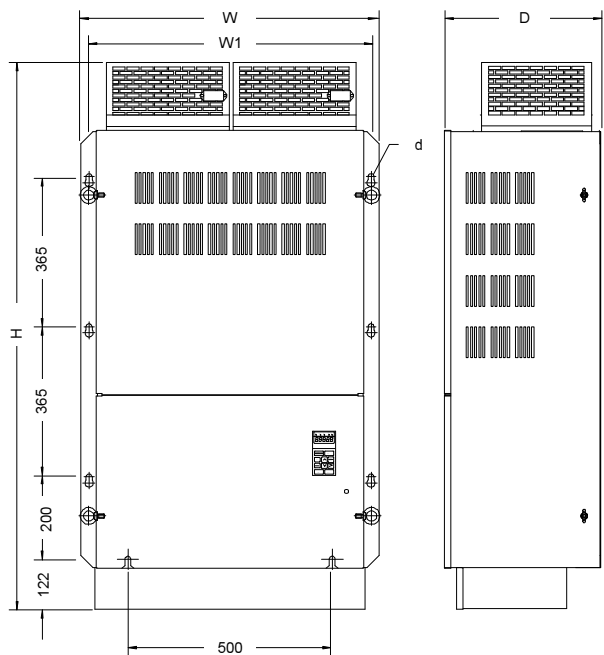

(Wall-mounted Type – NEMA1)

2. DESCRIPTION OF USING 7200GS/GS510

2.1 Using LCD (or LED) digital operator

- 7200GS/GS510 are standard with LCD digital operator JNEP-32. Moreover, an LED digital operator JNEP-33 is also available. Three two digital operator have the same operation functions except the LCD and 7-segments LED display difference.
- The LCD and LED digital operator has 2 modes: DRIVE mode and PRGM mode. When the inverter is stopped, DRIVE mode or PRGM mode can be selected by pressing the key . In DRIVE mode, the operation is enabled. Instead, in the PRGM mode, the parameter settings for operation can be changed but the operation is not enabled.

a. The LCD digital operator component names and functions shown as below:

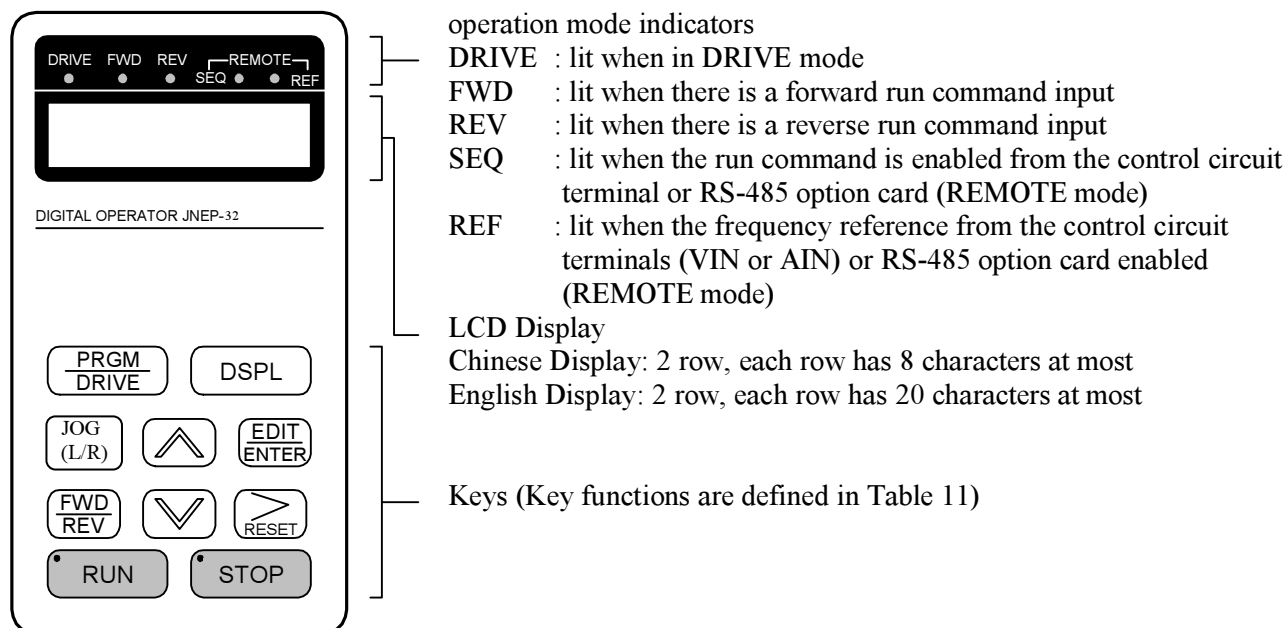

Fig 9-a LCD Digital operator component names and functions

b. The LED digital operator component names and functions shown as below:

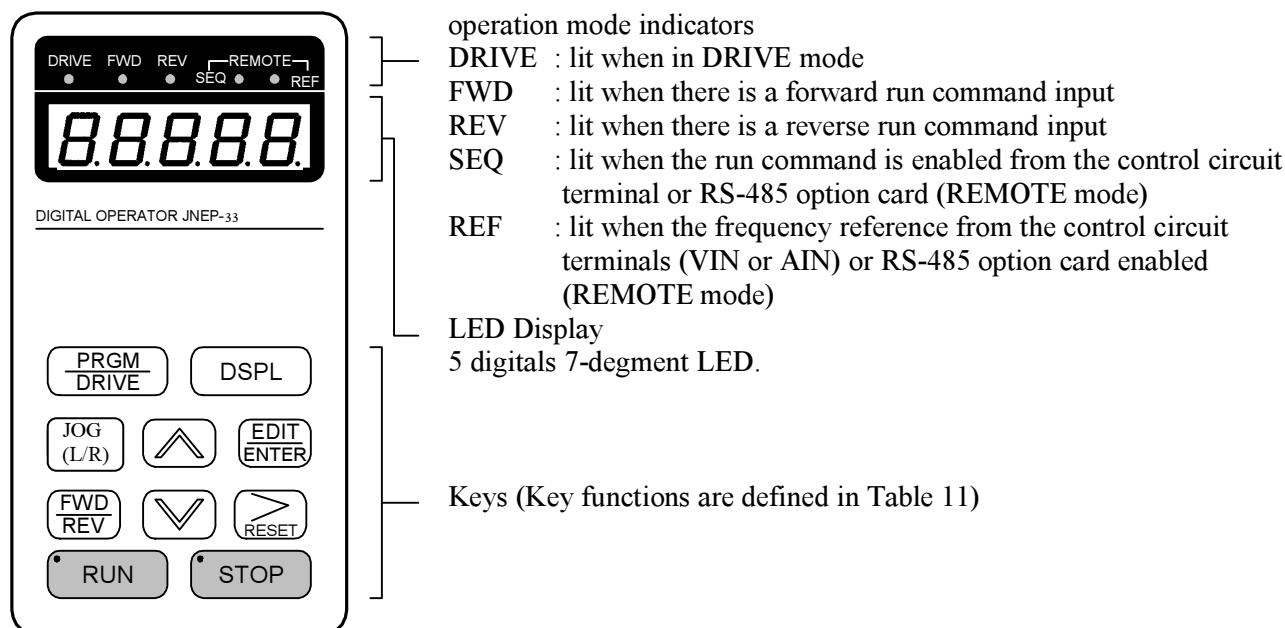









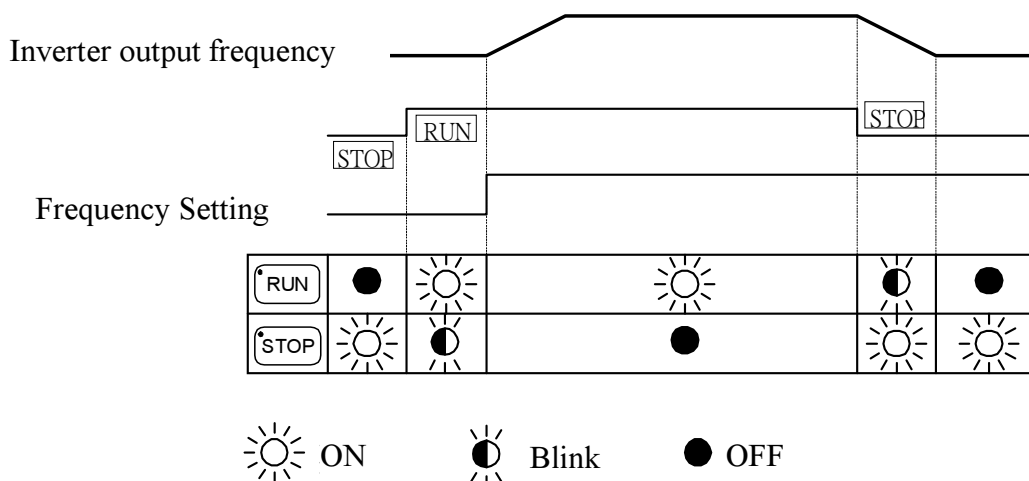

Fig 9-b LED Digital operator component names and functions

Table 11 Key's functions

Key	Name	Function
	PRGM/DRIVE key	Switches between operation (PRGM) and operation (DRIVE).
	DSPL key	Display operation status
	JOG or L/R key	Enable jog operation from digital operator in operation (DRIVE).L/R (Local/Remote)key function set by Sn-05.
	FWD/REV key	Select the rotation direction from digital operator.
	RESET key	Set the number of digital for user constant settings. Also it acts as the reset key when a fault has occurred.
	INCREMNT key	Select the menu items, groups, functions, and user constant name, and increment set values.
	DECREMENT key	Select the menu items, groups, functions, and user constant name, and decrement set values.
	EDIT/ENTER key	Select the menu items, groups, functions, and user constants name, and set values (EDIT). After finishing the above action, press the key (ENTER).
	RUN key	Start inverter operation in (DRIVE) mode when operator is used. The led will light.
	STOP key	Stop7200GS/GS510 operation from LCD digital operator. The key can be enable or disabled by setting a constant Sn-05 when operating from the control circuit terminal (in this case, the LED will light).

RUN, STOP indicator lights or blinks to indicate the 3 operating status:



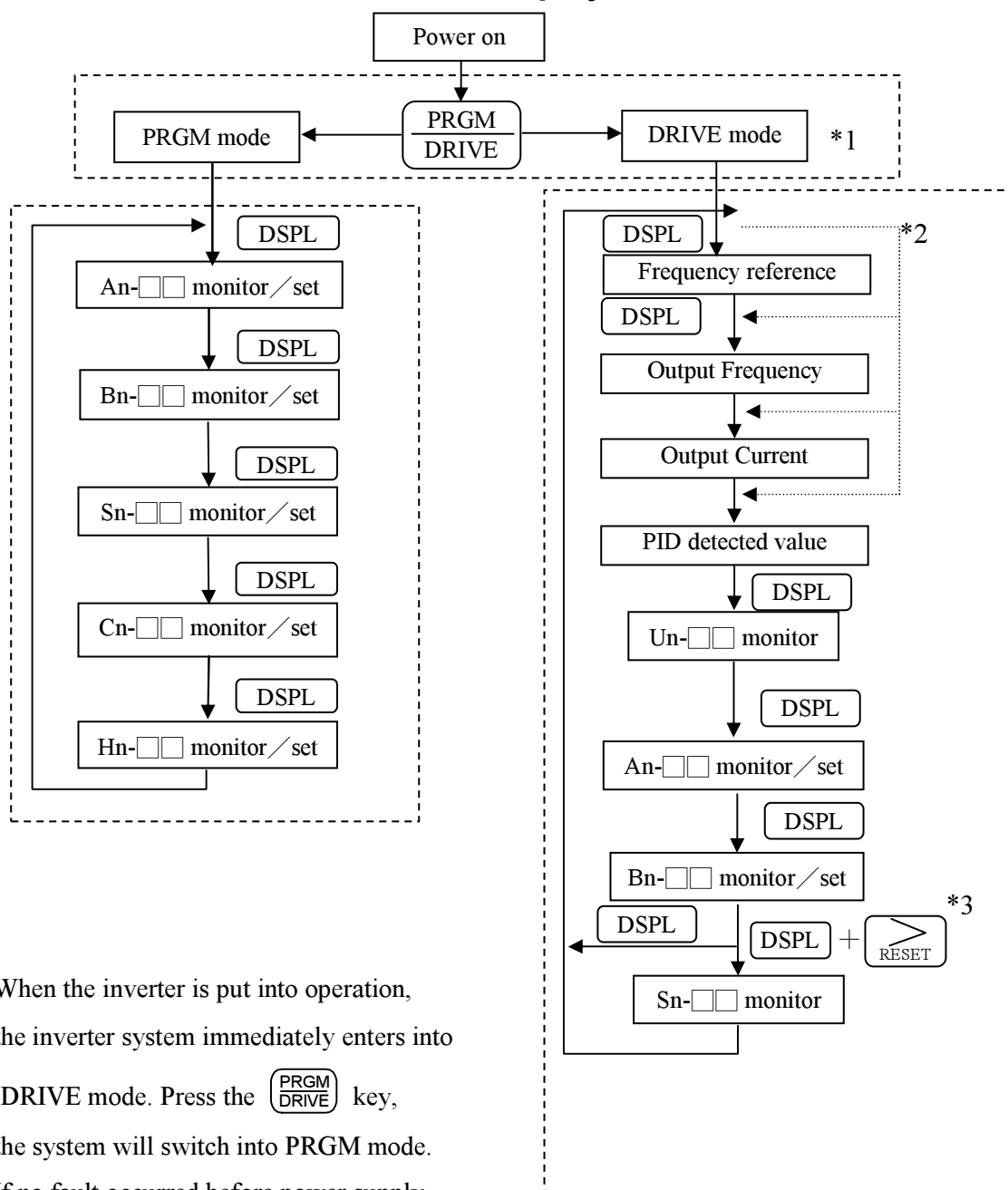

2.2 DRIVE mode and PRGM mode displayed contents



*1 : When the inverter is put into operation, the inverter system immediately enters into DRIVE mode. Press the  key, the system will switch into PRGM mode.

*2 : If no fault occurred before power supply was turned off , display the monitored data according to the Bn-10 setting

*3 : When in the DRIVE mode, press the  key and  key, the setting values of Sn- and Cn-□□ will only be displayed for monitoring but not for changing or setting.

2.3 Parameter description



The 7200GS/GS510 has 4 groups of user parameters:

Parameters ^{*4}	Description
An-□□	Frequency command
Bn-□□	Parameter settings can be changed during running
Sn-□□	System parameter settings (can be changes only after stop)
Cn-□□	Control parameter settings (can be changed only after stop)

The parameter setting of Sn-03 (operation status) will determine if the setting value of different parameter groups are allowed to be changed or only to be monitored, as shown below:

Sn-03	DRIVE mode		PRGM mode	
	To be set	To be monitored	To be set	To be monitored
0000 ^{*1}	An, Bn	Sn, Cn	An, Bn, Sn, Cn	—
0101 ^{*2}	An	Bn, Sn, Cn	An	Bn, Sn, Cn

*1 : Factory setting

*2 : When in DRIVE mode, the parameter group Sn-, Cn- can only be monitored if the  key and the  key are to be pressed at the same time,

*3 : After a few trial operation and adjustment, the setting value Sn-03 is set to be "0101" so as not be modified again.

*4 : The 7200GS/GS510 has 2 groups of monitoring parameters and one group of order parameters in addition to the above 4 groups of user parameters.

Un-□□ : Can be monitored by the users under the DRIVE mode.

Hn-□□ : Can be monitored by the users under the PRGM mode.

*5 : On-□□ : Order parameters can be monitored and changed by setting Sn-03=1010.

2.4 Example of using LCD digital operator

Note :

Before operation: Control parameter Cn-01 value must be set as the input AC voltage value. For example, Cn-01=380 if AC input voltage is 380.

This sample example will explain the operating of 7200GS/GS510 according to the following time chart.

OPERATION MODE

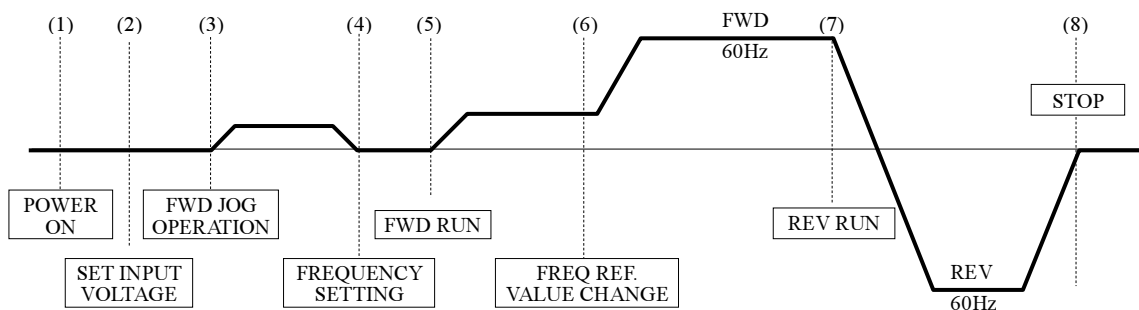

Sample operation

Description	Key Sequence	Digital Operator Display	Remarks
<p>(1) When POWER ON</p> <ul style="list-style-type: none"> ● Sect frequency reference value displayed ● Select PRGM mode <p>(2) Input voltage setting (e.g. AC input voltage is 380V)</p> <ul style="list-style-type: none"> ● Select CONTROL PARAMETER ● Display Cn-01 setting ● Input Voltage 380V <p>(continued)</p>	<p>PRGM DRIVE</p> <p>DSPL Press 3 times</p> <p>EDIT ENTER</p> <p>RESET ↑ ↓</p> <p>EDIT ENTER</p>	<p>Freq. Cmd. 00.00Hz TECO</p> <p>An-01 Freq. Cmd. 1</p> <p>Cn-01- Input Voltage</p> <p>Cn-01=440.0V Input Voltage</p> <p>Cn-01=380.0V Input Voltage</p> <p>Entry Accepted</p>	<p>LED DRIVE OFF</p> <p>Display for 0.5 sec</p>

Description	Key Sequence	Digital Operator Display	Remarks
(continued)			
<p>(3) FWD JOG</p> <ul style="list-style-type: none"> Select DRIVE mode Select output frequency displayed Select direction of rotation (When power on, initially defaulted FWD) Jog operation 	<p>PRGM / DRIVE</p> <p>DSPL</p> <p>JOG</p>	<p>Freq. Cmd. 00.00Hz TECO</p> <p>Freq. Cmd. .0 Hz TECO</p> <p>O/P Freq. 6.00 Hz TECO</p>	<p>LED DRIVE ON</p> <p>LED FWD ON</p>
<p>(4) Frequency setting</p> <p>15Hz</p> <ul style="list-style-type: none"> Select frequency cmd displayed Change frequency cmd Set new frequency cmd Select O/P frequency displayed 	<p>DSPL Press 4 times</p> <p>RESET ↑ ↓</p> <p>EDIT / ENTER</p> <p>DSPL</p>	<p>Freq. Cmd. 00.00Hz TECO</p> <p>Freq. Cmd. 15.00Hz TECO</p> <p>Freq. Cmd. 15.00Hz TECO</p> <p>Entry Accepted</p> <p>O/P Freq. .0 Hz TECO</p>	<p>Display for 0.5 sec Confirm the display.</p>
<p>(5) FWD run</p> <ul style="list-style-type: none"> Running operation 	<p>RUN</p>	<p>O/P Freq. 15.00 Hz TECO</p>	<p>LED RUN ON</p>
<p>(6) Frequency command change</p> <p>60Hz</p> <ul style="list-style-type: none"> Select frequency cmd displayed Change reference value Enter new frequency cmd setting Select frequency cmd displayed 	<p>DSPL Press 4 times</p> <p>RESET ↑ ↓</p> <p>EDIT / ENTER</p> <p>DSPL</p>	<p>Freq. Cmd. 15.00Hz TECO</p> <p>Freq. Cmd. 60.00Hz TECO</p> <p>Freq. Cmd. 60.00Hz TECO</p> <p>Entry Accepted</p> <p>O/P Freq. 60.00 Hz TECO</p>	<p>Display for 0.5 sec Confirm the display.</p>
<p>(7) REV RUN</p> <ul style="list-style-type: none"> Change to REV 	<p>FWD / REV</p>	<p>O/P Freq. -60.00 Hz TECO</p>	<p>LED REV ON</p>
<p>(8) STOP</p> <ul style="list-style-type: none"> Decrement to STOP 	<p>STOP</p>	<p>O/P Freq. .0 Hz TECO</p>	<p>LED STOP ON</p> <p>(Blinking while decel.) RUN</p>

3. SETTING USER CONSTANT

3.1 Frequency command (in Multi-speed operation) An-□□

Under the DRIVE mode, the user can monitor the parameters and set their values.

Parameter No.	Name	LCD Display (English)	Setting Range	Setting Unit	Factory Setting	Ref. Page
An-01	Frequency Command 1	An-01=000.00Hz Frequency Command 1	0.00~400.00 Hz	0.01Hz	00.00Hz	2-51 2-52 App-3
An-02	Frequency Command 2	An-02=000.00Hz Frequency Command 2	0.00~400.00 Hz	0.01Hz	0.00Hz	
An-03	Frequency Command 3	An-03=000.00Hz Frequency Command 3	0.00~400.00 Hz	0.01Hz	0.00Hz	
An-04	Frequency Command 4	An-04=000.00Hz Frequency Command 4	0.00~400.00 Hz	0.01Hz	0.00Hz	
An-05	Frequency Command 5	An-05=000.00Hz Frequency Command 5	0.00~400.00 Hz	0.01Hz	0.00Hz	
An-06	Frequency Command 6	An-06=000.00Hz Frequency Command 6	0.00~400.00 Hz	0.01Hz	0.00Hz	
An-07	Frequency Command 7	An-07=000.00Hz Frequency Command 7	0.00~400.00 Hz	0.01Hz	0.00Hz	
An-08	Frequency Command 8	An-08=000.00Hz Frequency Command 8	0.00~400.00 Hz	0.01Hz	0.00Hz	
An-09	Jog Frequency Command	An-09=006.00Hz Jog Command	0.00~400.00 Hz	0.01Hz	6.00Hz	

*1. The displayed "Setting Unit" can be changed through the parameter Cn-20.

*2. At factory setting, the value of "Setting Unit" is 0.01Hz.

3.2 Parameters Can Be Changed during Running Bn-□□

Under the DRIVE mode, the Parameter group can be monitored and set by the users.

Function	Parameter No.	Name	LCD Display (English)	Setting Range	Setting Unit	Factory Setting	Ref. Page
Acc/Dec time	Bn-01	Acceleration Time 1	Bn-01=0010.0s Acc. Time 1	0.0~6000.0s	0.1s	10.0s	2-4
	Bn-02	Deceleration Time 1	Bn-02=0010.0s Dec. Time 1	0.0~6000.0s	0.1s	10.0s	
	Bn-03	Acceleration Time 2	Bn-03=0010.0s Acc. Time 2	0.0~6000.0s	0.1s	10.0s	
	Bn-04	Deceleration Time 2	Bn-04=0010.0s Dec. Time 2	0.0~6000.0s	0.1s	10.0s	
Analog Frequency Command	Bn-05	Analog Frequency Cmd. Gain (Voltage)	Bn-05=0100.0% ~Freq. Cmd. Gain	0.0~1000.0%	0.1%	100.0%	2-4
	Bn-06	Analog Frequency Cmd. Bias (Voltage)	Bn-06=0000.0% ~Freq. Cmd. Bias	-100.0%~100.0%	0.1%	0.0%	
Torque Boost	Bn-07	Auto torque Boost Gain (Ineffective in energy-saving mode)	Bn-07=1.0 Auto_Boost Gain	0.0~2.0	0.1	1.0	2-4
A01 bias	Bn-08	Multi-Function Analog Output A01 Bias	Bn-08 =00.0% ~Output A01 Bias	-25.0%~+25.0%	0.1%	0.0%	2-4
A02 bias	Bn-09	Multi-Function Analog Output A02 Bias	Bn-09 =00.0% ~Output A02 Bias	-25.0%~+25.0%	0.1%	0.0%	2-5
	Bn-10	Monitor No. After power ON	Bn-10=1 Power On Contents	1~4	1	1	2-5
A01 Gain	Bn-11	Multi-Function Analog Output A01 Gain	Bn-11=1.00 ~Output A01 Gain	0.01~2.55	0.01	1.00	2-5
A02 Gain	Bn-12	Multi-Function Analog Output A02 Gain	Bn-12=1.00 ~Output A02 Gain	0.01~2.55	0.01	1.00	2-5
PID Control	Bn-13	PID Detection Gain	Bn-13=01.00 PID Det. Gain	0.01~10.00	0.01	1.00	2-5 2-6
	Bn-14	PID Proportional Gain	Bn-14=01.0 PID P-Gain	0.0~10.0	0.1	1.0	
	Bn-15	PID Integral Gain	Bn-15=010.0s PID I-Time	0.0~100.0s	0.1s	10.0s	
	Bn-16	PID Differential Time	Bn-16=0.00s PID D-Time	0.00~1.00s	0.01s	0.00s	
	Bn-17	PID Bias	Bn-17=000% PID Bias	0~109%*1	1%	0%	
PID Sleep Mode	Bn-18	PID sleep Frequency	Bn-18=000.00Hz PID Sleep Frequency	0.00~400.00Hz	0.01Hz	00.00Hz	2-6 2-7
	Bn-19	PID sleep/Wake-up Delay Time	Bn-19=000.0s PID Sleep Time	0.0~255.5Sec	0.1s	00.0s	
	Bn-20	PID Wake Up Frequency	Bn-20=60.00 Hz Wake_Up Frequency	0.00~400.00Hz	0.01Hz	60.00Hz	

*1. Cn-04 is to be the 100% level.

Function	Parameter No.	Name	LCD Display (English)	Setting Range	Setting Unit	Factory Setting	Ref. Page
PID Display unit	Bn-21	PID Detected Value Display Bias	Bn-21=0.000 PID Det. DSPL Bias	-9.999~+9.999	0.001	0.000	2-8
	Bn-22	PID Detected Value Display Gain	Bn-22=0.000 PID Det. DSPL Gain	0.000~9.999	0.001	0.000	2-8
PA-PID Relay Card Control Function	Bn-23	Freq. Command Upper-Bound Delay Time	Bn-23=300s Up-Bound Delay Time	1~600sec	1s	300s	2-9
	Bn-24	Freq. Command Lower-Bound Delay Time	Bn-24=300s Low-Bound Delay Time	1~600sec	1s	300s	2-9
	Bn-25	MC ON/OFF Delay Time	Bn-25=1.00s MC ON/OFF Delay Time	0.10~2.00sec	0.01s	1.00s	2-9
	Bn-26	Pump ON/OFF Detection Level	Bn-26=00.0% PUMP ONOFF Det. Level	0.0~20.0%	0.1%	0.0%	2-9
Motor Slip	Bn-27	Rated Slip of Motor	bn-08 =0.0% Motor Rated Slip	0.0~9.9%	0.1%	0.0%	2-10

3.3 Control Parameters C n - □ □

Function	Parameter No.	Name	LCD Display (English)	Setting Range	Setting Unit	Factory Setting	Ref. Page
V/F Pattern Setting	Cn-01	Input Voltage	Cn-01=220.0V Input Voltage	150~255.0V* ¹	0.1V	220.0V* ²	2-13 2-32
	Cn-02	Max. Output Frequency	Cn-02=060.0Hz Max. O/P Freq.	50.0~400.0Hz	0.1Hz	60.0Hz* ⁷	
	Cn-03	Max. Output Voltage	Cn-03=220.0V Max. Voltage	0.1~255.0V* ¹	0.1V	220.0V* ^{2,*7}	
	Cn-04	Max. Voltage Frequency	Cn-04=060.0Hz Max. Volt. Frequency	0.1~400.0Hz	0.1Hz	60.0Hz* ⁷	
	Cn-05	Middle Output Frequency	Cn-05=030.0Hz Middle O/P Freq.	0.1~400.0Hz	0.1Hz	30.0Hz* ⁷	
	Cn-06	Voltage At Middle Output Frequency	Cn-06=055.0V Middle Voltage	0.1~255.0V* ²	0.1V	55.0V* ^{1,*7}	
	Cn-07	Min Output Frequency	Cn-07=001.5Hz Min O/P Freq.	0.1~400.0Hz	0.1Hz	1.5Hz* ⁷	
	Cn-08	Voltage At Min. Output Frequency	Cn-08=008.0V Min. Voltage	0.1~255.0V* ²	0.1V	8.0V* ^{1,*7}	
Current Base	Cn-09	Motor Rated Current	Cn-09=031.0A Motor Rated I	* 3	0.1A	31A* ⁴	2-13
DC Braking Function	Cn-10	DC Injection Braking Starting Frequency	Cn-10=01.5Hz DC Braking Start F	0.1~10.0Hz	0.1Hz	1.5Hz* ⁷	2-13 2-14
	Cn-11	DC Braking Current	Cn-11=050% DC Braking Current	0~100%	1%	50%	
	Cn-12	DC Injection Braking Time At Stop	Cn-12=00.0s DC Braking Stop Time	0.0~25.5s	0.1s	0.0s	
	Cn-13	DC Injection Braking Time At Start	Cn-13=00.0s DC Braking Start T	0.0~25.5s	0.1s	0.0s	
Frequency Limit	Cn-14	Frequency Command Upper Bound	Cn-14=100% Freq. Cmd. Up Bound	0~109%	1%	100%	2-14
	Cn-15	Frequency Command Lower Bound	Cn-15=000% Freq. Cmd. Low Bound	0~109%	1%	0%	
Frequency Jump	Cn-16	Frequency Jump Point 1	Cn-16=000.0Hz Frequency Jump 1	0.0~400.0Hz	0.1Hz	0.0Hz	2-15
	Cn-17	Frequency Jump Point 2	Cn-17=0.0Hz Frequency Jump 2	0.0~400.0Hz	0.1Hz	0.0Hz	
	Cn-18	Frequency Jump Point 3	Cn-18=0.0Hz Frequency Jump 3	0.0~400.0Hz	0.1Hz	0.0Hz	
	Cn-19	Jump Frequency Width	Cn-19=01.0Hz Freq. Jump Width	0.0~25.5Hz	0.1Hz	1.0Hz	
Display Unit	Cn-20	Digital Operator Display Unit	Cn-20=00000 Operator Disp. Unit	0~39999	1	0	2-15
Agreed Speed Detection	Cn-21	Frequency Agree Detection Level	Cn-21=000.0Hz F Agree Det. Level	0.0~400.0Hz	0.1Hz	0.0Hz	2-16
	Cn-22	Frequency Agree Detection Width	Cn-22=02.0Hz F Agree Det. Width	0.1~25.5Hz	0.1Hz	2.0Hz	
Carrier Frequency	Cn-23	Carrier Frequency Upper Limit	Cn-23=6.0KHz Carry-Freq Up Bound	0.4~6.0KHz* ⁵	0.1KHz	6.0KHz* ⁵	2-17
	Cn-24	Carrier Frequency Lower Limit	Cn-24=6.0KHz Carry-Freq Low Bound	0.4~6.0KHz* ⁵	0.1KHz	6.0KHz* ⁵	
	Cn-25	Carrier Frequency proportion Gain	Cn-25=00 Carry-Freq P_ Gain	0~99	1	0* ⁵	

Function	Parameter No.	Name	LCD Display (English)	Setting Range	Setting Unit	Factory Setting	Ref. Page
OVER-Torque Detection	Cn-26	Overtorque Detection Level	Cn-26=160% Over Tq. Det. Level	30~200%	1%	160%	2-17
	Cn-27	Overtorque Detection Time	Cn-27=00.1s Over Tq. Det. Time	0.0~25.5s	0.1s	0.1s	
Stall Prevention	Cn-28	Stall Prevention Level During Acceleration	Cn-28=150% ACC. Stall	30~200%	1%	150%	2-17
	Cn-29	Not used	Cn-29=000 Reserved	00~000	—	—	—
	Cn-30	Stall Prevention Level During Running	Cn-30=130% Running Stall	30~200%	1%	130%	2-17
Communication Fault	Cn-31	Communication Fault Detection Time	Cn-31=01.0s Comm. Flt. Det. Time	0.1~25.5s	0.1s	1s	2-18
Frequency Detection	Cn-32	Frequency Detection 1 Level	Cn-32=000.0Hz Freq.Det. 1 Level	0.0~400.0Hz	0.1Hz	0.0Hz	2-18
	Cn-33	Frequency Detection 2 Level	Cn-33=000.0Hz Freq.Det. 2 Level	0.0~400.0Hz	0.1Hz	0.0Hz	2-18
—	Cn-34	Not used	Cn-34=0 Reserved	0~0	—	—	—
OL5 Control	Cn-35	Overload 5 detection time	Cn-35=0.0 OL5 Det time	0~255	1S	0S	2-20
Fault Retry	Cn-36	Number of Auto Restart Attempt	Cn-36=00 Retry Times	0~10	1	0	2-20 2-25
Ride-thru Time	Cn-37	Power Loss Ride-thru Time	Cn-37=2.0s Ride-Thru Time	0~2.0s	0.1s	2.0s*4	2-21
Speed Search Control	Cn-38	Speed Search Detection Level	Cn-38=150% SP_Search Level	0~200%	1%	150%	
	Cn-39	Speed Search Time	Cn-39=02.0s SP_Search Time	0.1~25.5s	0.1s	2.0s	
	Cn-40	Min. Baseblock Time	Cn-40=1.0s Min. B.B. Time	0.5~5.0s	0.1s	1.0s*4	
	Cn-41	V/F Curve in Speed Search	Cn-41=100% SP_Search V/F Curve	10~100%	1%	100%	
	Cn-42	Voltage Recovery Time	Cn-42=0.3s Voltage Recovery	0.1~5.0s	0.1s	0.3s	
PID Control	Cn-43	PID Integral Upper Bound	Cn-43=100% PID I-Upper	0~109%	1%	100%	2-22
	Cn-44	PID Primary Delay Time Constant	Cn-44=0.0s PID Filter	0.0~2.5s	0.1s	0.0s	
Energy-Saving Voltage Limit	Cn-45	Energy-Saving Volt. Upper Limit (60Hz)	Cn-45=120% Level 60 Hz	0~120%	1%	120%	2-22
	Cn-46	Energy-Saving Volt. Upper Limit (6Hz)	Cn-46=16% Level 6 Hz	0~25%	1%	16%	
	Cn-47	Energy-Saving Volt. Lower Limit (60Hz)	Cn-47=050% Level 60 Hz	0~100%	1%	50%	
	Cn-48	Energy-Saving Volt. Lower Limit (6Hz)	Cn-48=12% Level 6 Hz	0~25%	1%	12%	

Function	Parameter No.	Name	LCD Display (English)	Setting Range	Setting Unit	Factory Setting	Ref. Page
Energy-Saving Tuning operation	Cn-49	Tuning Operation Voltage Limit	Cn-49=00% Sav. Tuning V_Limit	0~20%	1%	0%	2-23
	Cn-50	Tuning Operation Control Cycle	Cn-50=01.0s Sav. Tuning period	0.1~10.0s	0.1s	1.0s	
	Cn-51	Tuning Operation Volt. Step (100% output Volt)	Cn-51=00.5% O/P Volt. 100%	0.1~10.0%	0.1%	0.5%	
	Cn-52	Tuning Operation Volt. Step (5% output Volt)	Cn-52=00.2% O/P Volt. 5%	0.1~10.0%	0.1%	0.2%	
Simplified Filter	Cn-53	UVL filter time	Cn-53=00.000 UVL Filter time	0.1~2.0s	0.1s	0.2s	2-23
	Cn-54	MC filter time	Cn-54=00.000 MC Filter time	0.1~2.0s	0.1s	0.2s	
Simplified Speed Control	Cn-55	Motor No Load Current	Cn-55=00.000 Motor No_Load I	00~99%	1%	30%	2-24
	Cn-56	Slip Compensation Delay time	Cn-56=00.000 Slip Comp Time	0.0~25.5s	0.1%	2.0s	
	Cn-57	Not used	Cn-57=000.00 Reserved	000.00~000.00	—	—	—
Energy-Saving Coefficient K2	Cn-58	Energy-Saving Coefficient K2 (60Hz)	Cn-58=115.74* ⁶ Eng. Saving Coeff	0.00~655.35	0.01	115.74* ⁶	2-24
	Cn-59	Energy-Saving Coefficient Reduction ratio (6Hz)	Cn-59=100% K2 Reduce Ratio	50~100%	1%	100%	2-25
	Cn-60	Motor Code	Cn-60=29* ⁴ Reserved	00~FF	—	29* ⁸	2-25
—	Cn-61	Not used	Cn-61=000 Reserved	000~000	—	—	—
Retry time	Cn-62	Auto Restart Time Interval	Cn-62=00s Retry time	0~20s	1s	0s	2-26
Motor Overheat time	Cn-63	Motor Overheat protection time	Cn-63=060s Motor OH time	1~300s	1s	60s	2-26

*1 For 220V class. × 2 for 440V class.

*2 For 220V class. × 2 for 440V class.

*3 Setting range becomes 10 to 200% of inverter rated current. The factory setting base on TECO AEEF standard 4 poles motor, 220V/60Hz, 440V/60Hz.

*4 Factory settings differ depending on inverter capacity (Sn-01 set value).

This example shows combination of TECO standard motor 440V 60Hz 25HP (18.5KW).
(Refer to the table on page 69)

At setting Sn-01, the set value changes to the factory setting. For any application other than TECO standard motors, set the value shown on the nameplate of the motor.

*5 Factory setting and setting, range differ depending on inverter capacity (Sn-01 set value).

*6 Differs depending on Cn-60 set value.

*7 Factory setting differ depending on V/F curve selection (Sn-02).

*8 The same value as Sn-01 is set.

3.4 System Parameters Sn-□□

Function	Parameter No.	Name	LCD Display (English)	Description	Factory Setting	Ref. Page
Capacity Setting	Sn-01	Inverter Capacity Selection	Sn-01=29 440V 25HP	Inverter Capacity Selection	*1	2-32 2-33
V/f Curve	Sn-02	V/f Curve Selection	Sn-02=2 V/f Curve	V/f pattern Selection	2	2-33
Operator Status	Sn-03	Operation Status	Sn-03=0000 Operate Setting	0000 : Setting and reading of An-□□, Bn-□□, Cn-□□, Sn-□□ enabled 0101 : Setting and reading of An-□□, Reading of Bn-□□, Cn-□□, Sn-□□ enabled 1110 : Contents Initialigation (2-wire)*2 1111 : Contents Initialigation (3-wire)*2 1000 : Initialize Un-11 contents 1001 : Initialize Un-12 contents	0000	2-36
Operation Mode Select	Sn-04	Operation Mode Select 1 (RUN · STOP Selection)	Sn-04=0011 Stopping Method	--0 : Frequency Command = Control circuit terminals VIN or AIN --1 : Frequency Command = Frequency Command 1 (An-01) -0- : RUN · STOP Command = Control circuit terminals -1- : RUN · STOP Command = Digital Operator 00- : Stopping method = Ramp to stop 01- : Stopping method =Coasting to stop 10- : Stopping method =Full-range DC injection braking stop 11- : Stopping method = Coasting stop (timer function provided)	0011	2-37 2-38 2-39
	Sn-05	Operation Mode Selection 2 (I/O terminal function selection)	Sn-05=0000 I/O Term. Fct.	--0 : Stop key effective during operation from control terminal --1 : Stop key effective during operation from control terminal -0- : Reverse run enabled -1- : Reverse run disabled -0- : Control input terminals ①~⑧ are scanned twice. -1- : Control input terminals ①~⑧ are scanned once. 0- : Digital operator  key = JOG key function 1- : Digital operator  key = L/R (Local/Remote) key function	0000	2-40
	Sn-06	Operation Mode Selection 3 (S-curve and frequency reference characteristics)	Sn-06=0000 S Curve & Cmd. Char.	--00 : S curve=0.2sec --01 : S curve=0.0sec (NO S curve) --10 : S curve=0.5sec --11 : S curve=1.0sec -0- : Reference command has forward characteristics (0-10V or 4-20mA/0~100%) -1- : Reference command has reverse characteristics (0-10V or 4-20mA/100~0%) 0- : Stop by reference input when frequency reference is missing 1- : Operation to continue with 80% of frequency reference when frequency reference is missing	0000	2-41 2-42 2-43

Function	Parameter No.	Name	LCD Display (English)	Description	Factory Setting	Ref. Page
Operation Mode Select	Sn-07	Operation Mode Selection 4 (overtorque detection)	Sn-07=0000 Over Tq. Detect	-- 0 : Overtorque detection not enabled -- 1 : Overtorque detection enabled - 0 - : Enabled only if at agreed frequency - 1 - : Enable during operation (except during DC injection) - 0 - - : Operation continued after overtorque is detected - 1 - - : Coasts to stop if overtorque is detected	0000	2-43 2-44
	Sn-08	Operation Mode Selection 5 (RS-485 communication status selection)	Sn-08=0011 RS485Comm. Function	-- 0 : Frequency reference input by RS-485 communication option card (PA-M or PA-P) -- 1 : Frequency reference input by digital operator or control circuit input terminals - 0 - : RUN/STOP command input by RS-485 Communication option card (PA-M or PA-P) - 1 - : RUN/STOP command input by digital operator or control circuit input terminals 00 - - : RS-485 communication fault, deceleration to stop (Bn-02) 01 - - : RS-485 communication fault, coast to stop 10 - - : RS-485 communication fault, deceleration to stop (Bn-04) 11 - - : RS-485 communication fault, continue to run	0011	2-44 2-45
	Sn-09	Operation Mode Selection 6 (Energy saving function selection)	Sn-09=0000 Eng. Saving Function	- 0 - - : Energy-saving function ineffective(V/F Control) - 1 - - : Energy-saving function ineffective	0000	2-45
Protective Characteristic Select 1	Sn-10	Protective Characteristic Selection 1 (Stall prevention)	Sn-10=0000 Stall Select	-- 0 : Stall prevention during acceleration enabled -- 1 : Stall prevention during acceleration not enabled - 0 - : Stall prevention during acceleration enabled - 1 - : Stall prevention during acceleration not enabled - 0 - - : Stall prevention during running enabled - 1 - - : Stall prevention during running not enabled 0 - - - : Decel time during stall prevention=Bn=02 set value 1 - - - : Decel time during stall prevention=Bn=04 set value	0000	2-45 2-46
Protective Characteristic Select 2	Sn-11	Protective Characteristic Selection 2 (Retry and momentary power failure protection)	Sn-11=0000 Retry & Ride_Thru	-- 0 : Input phase loss protection function ineffective -- 1 : Input phase loss protection function effective - 0 - : Fault contact is not energized during Retry operation - 1 - : Fault contact is energized during Retry operation - 0 - - : Operation stopped by momentary power loss detection (UV1) - 1 - - : Operation continues after momentary power loss 0 - - - : Output phase loss protection function ineffective 1 - - - : Output phase loss protection function effective	0000	2-46 2-47

Function	Parameter No.	Name	LCD Display (English)	Description	Factory Setting	Ref. Page	
Protective Characteristic Select 3	Sn-12	Protective Characteristic Selection 3 (External Fault signal function)	Sn-12=0100 External Fault	--0 : External fault input (terminal ③): NO-contact input --1 : External fault input: NC-contact input -0- : External fault signal: always detected -1- : External fault signal: detected during running only 00-- : External fault detected: Ramp to a stop (major fault) by Bn-02 set value 01-- : External fault detected: Coasting to stop (major fault) 10-- : External fault detected: Ramp to a stop (major fault) by Bn-04 set value 11-- : External fault detected: operation to continue (major fault)	0100	2-47	
Control Mode Select	Sn-13	Control Mode Select	Sn-13=01 V/F Ctrl mode	00 : Reserved 01 : V/F Control mode	01	2-47 2-48	
Protective Characteristic Select 4	Sn-14	Protective Characteristic Selection 5 (Electronic thermal overload protection)	Sn-14=0000 Over Load Select	--0 : Motor overload (OL1) protection effective --1 : Motor overload (OL1) protection ineffective -0- : Motor overload protection: standard motor -1- : Motor overload protection: Inverter duty motor -0-- : Motor overload protection time constants are standard time (8 minutes) -1-- : Motor overload protection time constants are short-time (5 minutes) 0-- : Cooling fan run while inverter power ON 1-- : Cooling fan run while heat sink temperature higher than 50°C	0000	2-48	
Multi-Function Select	Sn-15	Terminal ⑤ Function	Sn-15=03 Term.5 Function	00-66	Terminal ⑤ (factory preset for multi-step speed reference 1)	03	2-49 ~ 2-58
	Sn-16	Terminal ⑥ Function	Sn-16=04 Term.6 Function	00-66	Terminal ⑥ (factory preset for multi-step speed reference 2)	04	
	Sn-17	Terminal ⑦ Function	Sn-17=06 Term.7 Function	00-66	Terminal ⑦ (factory preset for jog frequency reference)	06	
	Sn-18	Terminal ⑧ Function	Sn-18=08 Term.8 Function	00-66	Terminal ⑧ (factory preset for external baseblock by NO contact input)	08	
	Sn-19	Terminal AUX Function	Sn-19=00 Multi-Fct \sqrt Input	00-0C	Terminal AUX (factory preset for auxiliary frequency command)	00	2-59 2-60
	Sn-20	Terminal R2A-R2C Function	Sn-20=00 Term. R2A Function	00-0F	Terminal R2A-R2C (factory preset for running)	00	2-63 ~ 2-64
	Sn-21	Terminal D01 Function	Sn-21=01 Term. D01 Function	00-0F	Terminal D01 (factory preset for zero speed)	01	
	Sn-22	Terminal R1A Function	Sn-22=02 Term. R1A Function	00-0F	Terminal R1A (factory preset for Agreed frequency)	02	

Function	Parameter No.	Name	LCD Display (English)	Description	Factory Setting	Ref. Page
RS-485 communication Function	Sn-23	Inverter station address	Sn-23=01 Inverter Address	Inverter address can be set as 1~31	01	2-65
	Sn-24	RS-485 communication protocol setting	Sn-24=1000 RS-485 protocol	--00 : No parity --01 : Even parity --10 : Odd parity --11 : not used } parity setting 00- : 2400 bps (bit/sec) 01- : 4800 bps 10- : 9600 bps 11- : 19200 bps } baud rate setting	1000	
Language	Sn-25	LCD Language displayed selection	Sn-25=0 Language select	0 : English 1 : Chinese	0	2-66
Multi-Function Analog Output Selection	Sn-26	Multi-Function Analog Output A01 Function Selection	Sn-26=00 Term. A01 Function	0 : Frequency command (10V/max frequency command, Cn-02) 1 : Output Frequency (10V/max Output frequency) 2 : Output Current (10V/inverter rated current) 3 : Output Voltage (10V/input voltage, Cn-01) 4 : DC Voltage (10V/400VDC or 800VDC) 5 : Output Power (10V/max. applicable motor capacity)	0	2-66
	Sn-27	Multi-Function Analog Output A02 Function Selection	Sn-27=01 Term. A02 Function	6 : External analog input command(VIN) (10V/10V) 7 : External analog input command(AIN) (10V/20mA) 8 : Multi-function analog input (AUX) (10V/10V) 9 : PID control feedback input (VIN+AIN) (10V/10V) A : RS-485 Communication Control	1	
Electronic Thermal Overload Protection	Sn-28	Over Load Select	Sn-28=0 Over Load Select	This function is effective only for 7200GS/GS510 air compressor inverter models with capacity 40HP(30kW) or larger (230V class), and 75HP (55kW) or larger (460V class). --01: Inverter overload (OL2) protection 103% continuous, 120% for one minute --10: Inverter overload (OL2) protection 103% continuous, 150% for one minute --11: Inverter overload (OL2) protection 113% continuous, 123% for one minute Motor over load (OL1) Select (apply to all class) 00- : Standard motor of 60Hz Overload protection 01- : Strengthen the standard motor (F class) of 60Hz Overload protection 10- : Standard motor of 50Hz Overload protection 11- : Strengthen the standard motor (F class) of 50Hz Overload protection	1010	2-66 2-67
Multi-function Analog Output Selection	Sn-29	Pulse Output Multiplier Selection	Sn-29=0 Pulse Mul.	when multi-function output terminal (DO1) is set as pulse signal output 0: 1 F 1 : 6 F 2 : 10 F 3 : 12 F 4 : 36 F	0	2-67

Function	Parameter No.	Name	LCD Display (English)	Description	Factory Setting	Ref. Page
PA-PID Card Function Selection	Sn-30	Pump Operation Mode Selection	Sn-30=0 Run-Mode Select	0 : PA-PID Card ineffective 1 : Fixed inverter driving mode, stop all the pumps by first-run-last-stop sequence. 2 : Fixed inverter driving mode, stop the pump driven by the inverter only. 3 : Fixed inverter driving mode, stop all the pumps by first-run-first-stop sequence. 4 : Cycled inverter driving mode, stop all the pumps by first-run-first-stop sequence. 5 : Cycled inverter driving mode, stop the pump driven by the inverter only.	0	2-68
PA-PID Card Relay Control	Sn-31	PA-PID Card Relay 2 Control	Sn-31=0 Invalid	0 : Relay 2 Invalid 1 : Relay 2 Valid	0	2-69
	Sn-32	PA-PID Card Relay 3 Control	Sn-32=0 Invalid	0 : Relay 3 Invalid 1 : Relay 3 Valid	0	
	Sn-33	PA-PID Card Relay 4 Control	Sn-33=0 Invalid	0 : Relay 4 Invalid 1 : Relay 4 Valid	0	
	Sn-34	PA-PID Card Relay 5 Control	Sn-34=0 Invalid	0 : Relay 5 Invalid 1 : Relay 5 Valid	0	
	Sn-35	PA-PID Card Relay 6 Control	Sn-35=0 Invalid	0 : Relay 6 Invalid 1 : Relay 6 Valid	0	
	Sn-36	PA-PID Card Relay 7 Control	Sn-36=0 Invalid	0 : Relay 7 Invalid 1 : Relay 7 Valid	0	
	Sn-37	PA-PID Card Relay 8 Control	Sn-37=0 Invalid	0 : Relay 8 Invalid 1 : Relay 8 Valid	0	
Parameter Copy	Sn-38	Parameter copy	Sn-38=0 Not Loaded	0 : Not loaded (not copied) 1 : Upload (from digital operator to inverter) 2 : Download (from inverter to digital operator) 3 : Inspect the EEPROM of digital operator	0	2-69 2-70
—	Sn-39	Not Used	Sn-39=0 Reserved	0 : Invalid	0	—

*1 Differs according to inverter capacity.

*2 Initialization (Sn-03 = 1110, 1111)

After depressing the **ENTER** key, input the initial value of An-□□, Bn-□□, Sn-□□, Cn-□□, (except Sn-01, Sn-02) into NV-RAM, When the value is written in without an error, "Entry Accepted" is displayed.

When the value is written in with an error, "□□**Error" is displayed. The values of Sn-15 to -18 differ as follows between initializations with Sn-03 = 1110 and with Sn-03 = 1111.

Multi-function Terminal	1110 (2 Wire Sequence)	1111 (3 Wire Sequence)
Terminal 5 (Sn-15)	3* (Multi-step speed command 1)	0 (FWD/REV run select)
Terminal 6 (Sn-16)	4* (Multi-step speed command 2)	3 (Multi-step speed reference 1)
Terminal 7 (Sn-17)	6* (Jog frequency reference)	4 (Multi-step speed reference 2)
Terminal 8 (Sn-18)	8* (External baseblock command)	6 (Jog frequency reference)

*Values have been factory-set.

**□□ Contents depend on the parameter setting items.

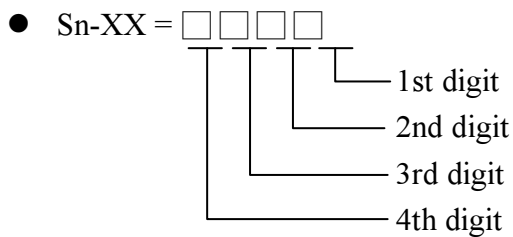

3.5 Monitoring Parameters Un-□□

Parameter No.	Name	LCD Display (English)	Unit	Descriptions
Un-01	Frequency Command	Un-01=60.00Hz Frequency Command	0.01Hz	Display frequency command, the displayed unit is determined by Cn-20
Un-02	Output Frequency	Un-02=60.00Hz Output Frequency	0.01Hz	Display output frequency, the displayed unit is determined by Cn-20
Un-03	Output Current	Un-03=12.5A Output Current	0.1A	Display inverter output current
Un-04	Output Voltage	Un-04=220.0V Output Voltage	0.1V	Display output voltage command of inverter
Un-05	Main Circuit DC Voltage	Un-05=310.0V DC Voltage	0.1V	Display DC voltage of inverter main circuit
Un-06	Output Power	Un-06= KW Output Power	0.1KW	Display output power of inverter
Un-07	Output Power Factor	Un-07=0.90 Output P.F.	0.01	Display output power factor of inverter
Un-08	Input Terminal Status	Un-08=00000000 I/P Term. Status	—	
Un-09	Output Terminal Status	Un-09=00000000 O/P Term. Status	—	
Un-10	S/W Version	Un-10=00001 Software Version	—	—Manufacturing use—
Un-11	Motor Elapsed Run Hours	Un-11=00001Hr Elapsed Time	1Hr	Display total time elapsed after pressing RUN (display data is resettable)*1
Un-12	Motor Elapsed Energy KWHR	Un-12=00001Kwh Elapsed Energy	1Kwh	Display total motor output energy (display data is resettable)*1

Parameter No.	Name	LCD Display (English)	Unit	Descriptions
Un-13	Option card code	Un-13=0 None Opt. Card	1	0 : None of option card is installed 1 : PA-L, PA-C card is installed in CN2. 2~5 : Reserved 6 : PA-P (PROFIBUS) card is installed in CN2. 7 : Reserved 8 : PA-PID card is installed in CN2.
Un-14	U phase current (IU) conversion value	Un-14=1.00V IU current	0.01V	Range : 0.00V ~ 5.00V ● Un-14, Un-15 can be used to check DCCT function. ● Un-16, Un-17 can be used to check ADC function in the control board. ● Troubleshooting used
Un-15	W phase current (IW) conversion value	Un-15=1.00V IW current		
Un-16	3 phase rectify current (DIAC) conversion value	Un-16=1.00V DIAC current		
Un-17	ADC Reference Volt. Conversion value	Un-17=2.50V ADCHK Voltage		
Un-18	External Analog Command VIN	Un-18=10.00V Voltage ~ Input	0.01V	Range : 0.00V ~ 10.00V
Un-19	External Analog Command AIN	Un-19=20.0mA Current ~ Input	0.1mA	Range : 0.0 ~ 20.0mA
Un-20	Multi-Function Analog Input Command AUX	Un-20=10.00V Multi-Fct. ~ Input	0.01V	Range : 0.00V ~ 10.00V
Un-21	PID Detected Value after display unit conversion	Un-21=1.000 PID Detect	0.001	<p>Range : -9.999 ~ +9.999 The display conversion unit depend on Bn-21 and Bn-22.</p> <p>PID detected Value after unit conversion (Un-21)</p>
Un-22	Fault Message 1	Un-22 Fault Message 1	—	Fault message occurred now
Un-23	Fault Message 2	Un-23 Fault Message 2	—	Fault message occurred last time
Un-24	Fault Message 3	Un-24 Fault Message 3	—	Fault message occurred last two time
Un-25	Fault Message 4	Un-25 Fault Message 4	—	Fault message occurred last three time
Un-26	Display In Drive Mode	GS VF Mode	—	Display VFD type and control mode(Drive mode)

*1 The contents of Un-11 and Un-12 can be reset by Sn-03=1000 and 1001

Individually.

*2 The display status for JNEP-33 LED operator : *3. The display status for JNEP-33 LED operator

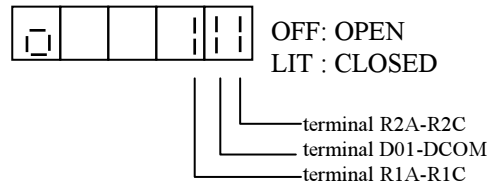
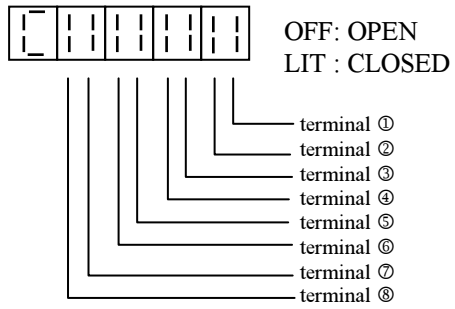

3.6 Monitoring Parameters Hn-□□

- The inverter input/output interface status can be monitored under the PRGM mode by Hn-□□ parameter.
- Hn-□□ parameter will toggle display with low voltage protection alarm (UV) if the UV alarm occurred.

Parameter No.	Name	LCD Display (English)	Unit	Descriptions
Hn-01	Main Circuit DC Voltage	Hn-01=622.0V DC Voltage	0.1V	Display DC voltage of inverter main circuit
Hn-02	Input Terminal Status	Hn-02=00000000 I/P Term. Status	—	<p>0 : OPEN 1 : CLOSE Input terminal ① Input terminal ② Input terminal ③ Input terminal ④ Input terminal ⑤ Input terminal ⑥ Input terminal ⑦ Input terminal ⑧</p>
Hn-03	Output Terminal Status	Hn-03=00000000 O/P Term. Status	—	<p>0 : OPEN 1 : CLOSE Relay Contact R2A-R2C Opto-contact D01-DCOM Opto-contact R1A-R1C Reversed Reversed Reversed Reversed</p>
Hn-04	Option card code	Hn-04=0 None Opt. Card	1	0 : None of option card is installed 1 : PA-M, PA-L, PA-C card is installed. 2~5 : Reserved 6 : PA-P, PA-L, PA-C card is installed . 7 : Reserved 8 : PA-PID card is installed.
Hn-05	U phase current (IU) conversion value	Hn-05=2.50V IU current	0.01V	Range : 0.00V ~ 5.00V ● Hn-05, Hn-06 can be used to check DCCT function. ● Hn-07, Hn-08 can be used to check ADC function in the control board. ● Troubleshooting used.
Hn-06	W phase current (IW) conversion value	Hn-06=2.50V IW current		
Hn-07	3 phase rectify current (DIAC) conversion value	Hn-07=1.00V DIAC current		
Hn-08	ADC Reference Volt. conversion value	Hn-08=2.50V ADCHK Voltage		

Parameter No.	Name	LCD Display (English)	Unit	Descriptions
Hn-09	External Analog Command VIN	Hn-09=10.00V Voltage ~ Input	0.01V	Range : 0.00V ~ 10.00V
Hn-10	External Analog Command AIN	Hn-10=20.0mA Current ~ Input	0.1mA	Range : 0.0 ~ 20.0mA
Hn-11	Multi-Function Analog Input Command AUX	Hn-11=10.00V Multi-Fct. ~ Input	0.01V	Range : 0.00V ~ 10.00V
Hn-12	Motor Elapsed Run Hours	Hn-12=00001Hr Elapsed Time	1Hr	Display total time elapsed after pressing RUN (display data is resetable)
Hn-13	S/W Version	Hn-13=00001 Software Version	—	— Manufacturing use —
Hn-14	Display In PRGM Mode	GS VF Mode	—	Display VFD type and control mode(Prgm mode)

3.7 Order Parameters On-□□

- Order parameters are already set to the optimum value as initial values, adjustment is not needed in the normal status.

Function	Parameter NO.	Name	LCD Display (English)	Description	Factory Setting
Control StatusPI	On-01	Control Status 1	On-01=0000 Control Status 1	XX0X : stored the frequency reference in the HOLD status (for up/down operation) XX1X : Do not store the frequency reference in the HOLD status X0XX : PID Feedback zero input protection invalid X1XX : PID Feedback zero input protection valid	0000
	On-02	Control Status 2	On-02=0000 Control Status 2	XXX0 : Inverter overload protection (OL2) valid XXX1 : Inverter overload protection (OL2) invalid XX0X : AVR function valid XX1X : AVR function invalid 0XXX : OL2&OL5 reset timer 5min valid 1XXX : OL2&OL5 reset timer 5min Invalid	0000
	On-03	Control Status 3	On-03=0000 Control Status 3	XXX0 : Anti-hunting gain change depending on inverter output voltage XXX1 : Anti-hunting gain depending on On-07 setting XX0X : Two-phase PWM modulation XX1X : Three-phase PWM modulation X0XX : Power angle compensation bias change depending on inverter output frequency X1XX : Power angle compensation bias fixed	0000
	On-04	PID control mode selection	On-04=0000 Reserved	XXX0 : Bias D control XXX1 : Feedback D control XX0X : PID output forward characteristics control XX1X : PID output reversed characteristics control X0XX : Frequency command=PID output X1XX : Frequency command=PID output+ Frequency command 0XXX : Forward characteristics PID feedback 1XXX : Reversed characteristics PID feedback	0000
—	On-05	Not used	On-05=0 Reserved	—	0.00
	On-06	Not used	On-06=0 Reserved	—	0
Hunting Prevention control	On-07	Hunting Prevention gain	On-07=0.10 Hunt Prev. Gain	Setting range : 0.01 ~ 2.55	0.10
	On-08	Hunting Prevention limit	On-08=030% Hunt Prev. Limit	Setting range : 0 ~ 100%	30%*1
Effective current detection control	On-09	Effective current detection filter time constant	On-09=005 I_Det. Time const	Setting range : 1 (3.5ms) ~ 100 (350ms)	5*1 (17.5ms)
	On-10	Not used	On-10=0 Reserved	—	0
On-delay control	On-11	ON-DELAY TIME	On-11=011 ON-Delay Time	Setting range : 11 (2.75μs) ~ 160 (40μs), Δ=0.25μs	11 (2.75μs)
	On-12	ON-DELAY Compensated value	On-12=014 ON-Delay Compen.	Setting range : 0 ~ 160 (40μs), Δ=0.25μs	14 (3.5μs)
—	On-13	Not used	On-13=0 Reserved	—	0
	On-14	Not used	On-14=0 Reserved	—	0

Function	Parameter NO.	Name	LCD Display (English)	Description	Factory Setting
Energy Saving power detection	On-15	Power detection filter changing width	On-15=010% Power Det. Dead Zone	Setting range : 0 ~100% Setting unit : 1%	10%
	On-16	Power detection filter time constant	On-16=020 Power Det. Time Const.	Setting range : 1 ~255 Setting unit : 1 (=7ms)	20 (140ms)
Torque Boost Control	On-17	Motor phase to phase resistance	On-17=00.308Ω Motor Line R	Setting range : 0 ~ 65.535Ω Setting unit : 0.001Ω	0.308Ω* ¹
	On-18	Torque Compensation of care loss	On-18=425W Tq. Compens. Care Loss	Setting range : 0 ~ 65535W Setting unit : 1W	425W* ¹
	On-19	Torque Compensation limit	On-19=100V Tq. Compens. Limit	Setting range : 0 ~ 50V* ² Setting unit : 1V	100V* ¹
Energy- saving Motor Constant * ³	On-20	Motor Constant R1	On-20=00.000Ω Motor R1	Setting range : 0.000 ~ 65.535Ω Setting unit : 0.001Ω	0.000Ω
	On-21	Motor Constant R2	On-21=00.000Ω Motor R2	Setting range : 0.000 ~ 65.535Ω Setting unit : 0.001Ω	0.000Ω
	On-22	Motor Constant L	On-22=00.000mH Motor L	Setting range : 0.000 ~ 65.535mH Setting unit : 0.001mH	0.000mH
	On-23	Motor Constant Rm	On-23=00.000mΩ/ω Motor Rm	Setting range : 0.000 ~ 65.535mΩ/ω Setting unit : 0.001mΩ/ω	0.000mΩ/ω
	On-24	Motor Constant Lm	On-24=00.00mH Motor Lm	Setting range : 0.00 ~ 655.35mH Setting unit : 0.01mH	0.00mH

*1. Factory setting differ depending on inverter capacity (Sn-01 set value).

This example shown combination of TECO standard motor 440V, 60Hz, 25HP (18.5KW).

*2. For 220V class, X2 for 440V class.

*3. ● Setting can be made only when Cn-60=FFH. When the value is changed, K2 (Energy-saving Coefficient K2) is calculated and the calculated value is set to Cn-58.

● Motor constants (On-20 ~On-24) are not stored in NVRAM and become 0 at power startup.

● The unit and setting range change depending on the inverter capacity:

1/10 for 220V class 25HP ~ 125HP, 440V class 75HP ~ 500HP.

4. FAULT DISPLAY AND TROUBLESHOOTING

The 7200GS/GS510 has protection function and warning self-diagnosis function. If a fault occurs, the protection functions operate to shut off the inverter output and the motor coasts to a stop, at the same time, the fault contact signal (terminal R3A-R3C, R3B-R3C) is output.

A). PROTECTION FUNCTION AND TROUBLESHOOTING

Protection function		Explanation	LCD display (English)
Low voltage protection	Main circuit low voltage	When the inverter power voltage drops, torque becomes insufficient and motor is overheated. Inverter output is stopped when the main circuit DC voltage becomes lower than the low voltage detection level for 15 ms or longer. or about 2 seconds or longer if the momentary power loss redo-thru function is used. Detection level: Approximately 210V or less for 200V class and 420V or less for 400V class	Fault (UV1)* ¹ DC Volt. Low
	Momentary power loss protection		
	Control circuit low voltage	The inverter output is shut-off when the control circuit voltage drops below the low voltage level.	Fault (UV2)* ¹ Cont. Ckt Low Volt.
	Main circuit soft charge contactor defective	The inverter output is shut-off when no answer back is received from the main circuit soft-start contactor.	Fault (UV3)* ¹ MC Ans. Fault
Overcurrent protection		The inverter output is shut-off when the inverter output current becomes approx. 200% and above of inverter rated current.	Fault (OC)* ¹ Over Current
Ground-fault protection		The inverter output is shut-off when a ground-fault occurs at the inverter output side and the ground-fault current exceeds approximately 50% of the inverter rated current.	Fault (GF)* ¹ Ground Short
Overvoltage protection		The inverter output is shut-off when the main circuit DC voltage becomes excessive because of regeneration energy caused by motor deceleration and negative load. Detection. Approx. 800V for input voltage set 400V and above Level : Approx. 700V for input voltage set 400V or less and approx. 400V for 200V class	Fault (OV)* ¹ Over Voltage
Cooling fin overheat		The inverter output is shut-off when the ambient temperature rises and the heat sink fin reaches 105°C. Please check for a defective cooling fan or clogged filter.	Fault (OH)* ¹ Over Heat
Overload protection	Motor	Inverter output is stopped when motor overload is detected by the electronic thermal overload in the inverter. Either a inverter duty constant-torque specialized motor or general-purpose motor can be selected. If more than one motor is driven, overload protection should be disabled. Use a thermal relay or thermal protector for each motor.	Fault (OL1)* ¹ Motor Over Load
	Inverter	The inverter output is shut-off when the electronic thermal overload reaches or exceeds the inverse time limit of 103% of the inverter's rated current occurs. Maximum rated overload: 110%. 1 min.	Fault (OL2)* ¹ Inverter Over Load
	Over torque detection	The motor operates according to a preset mode when the inverter output current exceeds the overtorque detection level. This function is used to protect the machine or to monitor the output torque.	Fault (OL3)* ¹ Over Torque
External fault signal input	Terminal ③	When an external alarm signal is input, the inverter operates according to a preset stop method (coasting to a stop, continuous operation, or ramp to stop)	Fault (EF3)* ¹ External Fault 3
	Terminal ⑤		Fault (EF5)* ¹ External Fault 5
	Terminal ⑥		Fault (EF6)* ¹ External Fault 6
	Terminal ⑦		Fault (EF7)* ¹ External Fault 7
	Terminal ⑧		Fault (EF8)* ¹ External Fault 8
Control Circuit Fault	Control Circuit Fault	The inverter output is shut-off when a transmission error occurs in the control circuit or a component fails. The inverter output is also shut-off when a specialized option such as the digital operator is not properly connected.	Fault (CPF02)* ¹ Cont.Ckt Fault
	EEPROM fault		Fault (CPF03)* ¹ EEPROM Fault
	EEPROM BCC CODE Error		Fault (CPF04)* ¹ EEPROM CODE Err.
	CPU ADC Fault		Fault (CPF05)* ¹ A/D Fault
	Option Card Fault		Fault (CPF06)* ¹ Opt. Card Improper

The warning and self-diagnosis functions do not operate fault contact output (except OH1 warning function) and returns to the former operation status automatically when the factor is removed.
The fault display and troubleshooting are provided as shown in the table below.

Fault Contact output	Error causes	Action to be taken
Operation	<ul style="list-style-type: none"> ● Inverter capacity is too small. ● Voltage drop due to wiring. ● Inverter power voltage selection is wrong ● A motor of large capacity (11 kW or greater) connected to the same power system has been started. ● Rapid acceleration with generator power supply ● Operation sequence when power is off ● Defective electromagnetic contactor 	<ul style="list-style-type: none"> ● Check the power capacity and power system. ● UV display appears when the inverter power is turned off while operation signal is input. Remove the power after stopping the inverter. ● (Set the third and fourth bits of Sn-04 to 01.)
Operation	<ul style="list-style-type: none"> ● Extremely rapid accel/decel ● Motor on/off switching at the inverter output side ● Short-circuit or ground-fault at the inverter output side ● Motor of a capacity greater than the inverter rating has been started ● High-speed motor or pulse motor has been started. 	Transistor error may occur. Investigate the error cause, correct it, then restart.
Operation	<ul style="list-style-type: none"> ● Motor dielectric strength is insufficient. ● Load wiring is not proper. 	Check for ground-fault in motor or load wiring.
Operation	<ul style="list-style-type: none"> ● Over voltage ● Insufficient deceleration time ● Regenerative load (Motor is turned by the load.) ● High input voltage compared to motor rated voltage 	If braking torque is not proper, extend the decel time or use a braking resistor. (If braking resistor is already installed, verify that Sn-10. 2nd digit to 1.)
Operation	<ul style="list-style-type: none"> ● Defective cooling fan. ● Ambient temperature rise ● Clogged filter 	Replace the cooling fan and clean the filter. Ambient temperature: 104°F (40°C) or less for enclosed type 122°F (45°C) or less for open chassis
Operation	Overload, low speed operation or extended acceleration time, improper V/f characteristic setting	Investigate the cause of overload and review the operation pattern, V/f characteristic, and motor/inverter capacities. (If inverter is repeatedly reset after an overload occurs, the inverter may fault. Investigate and correct the cause of overload.)
Operation	Motor current exceeds the preset value because of machine error or overload.	Check the use of the machine. Correct the overload cause or set a higher detection level which is within the allowable range.
Operation	External fault condition occurred.	Correct the Cause of the fault input.
Operation	<ul style="list-style-type: none"> ● External noise ● Excess vibration or shock ● CPF 02: Control circuit fault ● CPF 03: NVRAM (SRAM) fault ● CPF 04: NVRAM BCC Code error ● CPF 05: AD converter fault in CPU 	Check data in Sn-01 and Sn-02. Record all data, then use, Sn-03 for initializing. Turn off power, then turn on again. If error is persistent, contact your TECO representative.

Protection function		Explanation	LCD display (English)
Parameter Setting Error		Parameter Setting Error	Fault (Err)* ¹ Parameter
Input Phase Loss Fault		DC bus voltage ripple $\Delta V \geq$ input phase loss detection level (Cn-61), the motor coasts to stop	Fault (SPi)* ¹ Input phase loss
Output Phase Loss Fault		One of the inverter output phases are lost, the motor coasts to stop.	Fault (SPo)* ¹ Output phase loss
Motor overheat		The motor temperature detected sensor PTC thermistor $RT \geq 1330\Omega$	Fault (OH3)* ¹ Motor Overheat
RS-485 communication Fault	Fault 1	RS-485 communication error or transmission fault during communicating and the RS-485 stopping method after communication error of Sn-08 is to stop the motor.	(CPF21)* ¹ Comm. Fault 1
	Fault 2	RS-485 communication protocol error and the RS-485 stopping method after communication error of Sn-08 is to stop the motor	(CPF22)* ¹ Comm. Fault 2
	Fault 3	PROFIBUS communication option card PA-P Dual port RAM fault.	(CPF23)* ¹ Comm. Fault 3
	Fault 4	PROFIBUS communication option card PA-P EEPROM checksum error.	(CPF24)* ¹ Comm. Fault 4
	Fault 5	PROFIBUS communication option card PA-P RAM fault	(CPF25)* ¹ Comm. Fault 5
	Fault 6	PROFIBUS communication option card PA-P communication IC fault.	(CPF26)* ¹ Comm. Fault 6
	Fault 7	PROFIBUS communication option card PA-P Watch dog timer active.	(CPF27)* ¹ Comm. Fault 7
Overload protection	Inverter	The inverter output is shut-off when the electronic thermal overload reaches or exceeds the inverse time limit of 120% of the inverter's rated current occurs. Maximum rated overload: 150%. Cn-35 timer.	Fault (OL5)* ¹ Inverter Over Load
External fault PID Feedback	VIN/AIN	VFD does not receive Forward characteristics PID feedback signal within 60s.	Fault (PIDO)* ¹ PID feedback open

* 1. The display contents of LED digital operator.

Fault Contact output	Error causes	Action to be taken
Operation	Parameter setting error	
Operation	<ul style="list-style-type: none"> ● One of the inverter input phases are lost ● 3 phases power source are unbalance. ● The main circuit smooth capacitor are deteriorated. ● Improper input phase loss detection level (Cn-61) setting 	<ul style="list-style-type: none"> ● Check the inverter input power supply wiring. ● Check the capacitors. ● Check the setting of Cn-61.
Operation	<ul style="list-style-type: none"> ● One of the inverter output phases are lost ● DCCT fault. 	<ul style="list-style-type: none"> ● Check the wiring between inverter and motor. ● Replace the DCCT.
Operation	<ul style="list-style-type: none"> ● Motor load current is too large. ● The effective cooling of motor is not sufficient. 	<ul style="list-style-type: none"> ● Check the motor load current. ● Check the motor effective cooling.
Operation	<ul style="list-style-type: none"> ● RS-485 communication option card fault ● Excess vibration or shock ● External noise 	<ul style="list-style-type: none"> ● Turn off power, then turn on again. If error is persistent, replace the option card.
Operation	<ul style="list-style-type: none"> ● The RS-485 communication protocols setting inverter (Sn-24) and option card are inconsistent. 	<ul style="list-style-type: none"> ● Check the setting in Sn-24 and option card.
Operation	<ul style="list-style-type: none"> ● PA-P card fault 	<ul style="list-style-type: none"> ● Turn off power, then turn on again. If error is persistent, replace the option card.
Operation		
Operation		
Operation		
Operation		
Operation	Overload, low speed operation or extended acceleration time, improper V/f characteristic setting	Investigate the cause of overload and review the operation pattern, V/f characteristic, and motor/inverter capacities. (If inverter is repeatedly reset after an overload occurs, the inverter may fault. Investigate and correct the cause of overload.) .Cn-35=0, turn off.
Operation	Feedback signal or cable fault.	Check the PID cable is connected or not

B.) Warning and Self-Diagnosis Functions

Protection function		Explanation	LCD display (English)
Low-voltage protection (main circuit) voltage insufficient		Monitor display appears if low voltage protection conditions such as a drop in main circuit voltage or momentary power loss occur while the inverter output is off.	(blinking) Alarm (UV)* ¹ DC Volt. Low
High voltage protection		Monitor display appears when the main circuit DC voltage rises above the detection level while the inverter output is off.	(blinking) Alarm (OV)* ¹ Over Voltage
Cooling fin overheat warning		Monitor display appears when a separate thermal protector contact is input to the external terminal. (Sn-15 ~ 18 = OB)	(blinking) Alarm (OH2)* ¹ Over Heat
Overtorque detection		This function is used to protect the machine and to monitor the inverter output torque. The inverter output reacts in a preset manner when the inverter output current exceeds the over torque detection level. The monitor display blinks when "operation continue" is preset.	(blinking) Alarm (OL3)* ¹ Over Torque
Stall prevention (Accel/decel is accomplished with maximum capacity of the inverter without tripping on over-current or overvoltage a)	During acceleration	Inverter acceleration is stopped when 150% of or more of the inverter rated current is required by the load. This prevents overload protection (OL2) or overcurrent (OC) from occurring. When current is reduced to less than 170%, acceleration is enabled.	—
	During normal operation	Output frequency is decreased when 130% of the inverter rated current or greater is required by the load. This prevents motor and inverter overload (OL1, OL2). When current is reduced below 130%, inverter acceleration is then enabled.	—
	During deceleration	Deceleration is stopped when the DC voltage is caused to rise by motor regenerative energy. This prevents overvoltage trips (OV). When DC voltage decreases, deceleration to the set value then resumes	—
Simultaneous normal and reverse rotation commands		When forward and reverse rotation commands are simultaneously detected for a period of time exceeding 500 ms, the inverter is stopped according to the preset stop method.	(blinking) Alarm (EF)* ¹ Input Error
External Fault Signal Input (Minor fault)	Terminal ③	It is indicated on the monitor when the mode after external signal input is set to "Operation continue." ● Ref. to the external faults ⑤ ~ ⑧ setting on page 87 ● Minor fault setting — terminal ③ (Sn-12=11XX) terminal ⑤ (Sn-15=2C) terminal ⑥ (Sn-16=3C) terminal ⑦ (Sn-17=4C) terminal ⑧ (Sn-18=5C)	(blinking) Alarm (EF3)* ¹ External Fault 3
	Terminal ⑤		(blinking) Alarm (EF5)* ¹ External Fault 5
	Terminal ⑥		(blinking) Alarm (EF6)* ¹ External Fault 6
	Terminal ⑦		(blinking) Alarm (EF7)* ¹ External Fault 7
	Terminal ⑧		(blinking) Alarm (EF8)* ¹ External Fault 8
Digital Operator communication error		Operator transmission fault 1 (Initial fault)	Alarm (CPF00)* ¹ OP Comm. Fault
		Operator transmission fault 2 (on lime fault)	Alarm (CPF01)* ¹ OP Comm. Fault 2

Fault Contact output	Error causes	Action to be taken
Non Operation	<ul style="list-style-type: none"> ● Input voltage drop 	Check the main circuit DC voltage in Un-xx. If the voltage is low, adjust the input voltage.
Non Operation	<ul style="list-style-type: none"> ● Input voltage rise 	Check the main circuit DC voltage in Un-xx. If the voltage is high, adjust the input voltage.
Non Operation	<ul style="list-style-type: none"> ● Overload ● Cooling fan fault ● Ambient temperature rise ● Clogged filter 	Replace the cooling fan and clean the filter. Ambient temperature: 104°F (40°C) or less for enclosed type 122°F (45°C) or less for open chassis
Non Operation	<ul style="list-style-type: none"> ● Motor current exceeded the set value because of machine fault or overload. 	Check the driven machine and correct the cause of the fault or set to a higher value.
Non Operation	<ul style="list-style-type: none"> ● Insufficient power for accel/decel ● Overload ● Phase loss 	<ul style="list-style-type: none"> ● Set proper accel/decel time for smooth operation. ● For stall prevention during normal operation lighten the load or increase inverter capacity.
Non Operation	<ul style="list-style-type: none"> ● Operation sequence error ● 3-wire/2-wire selection error 	<ul style="list-style-type: none"> ● Recheck the control sequence. ● Recheck system constant (Sn-15 to -18)
Non Operation	<ul style="list-style-type: none"> ● External fault conditions set-up 	Take appropriate measurement for the cause of external fault input.
Non Operation	<ul style="list-style-type: none"> ● Transmission between the inverter and digital operator cannot be established 5 seconds after supplying power. ● Transmission between the inverter and digital operator is established once after supplying power, but later transmission fault continued for more than 2 seconds. 	<ul style="list-style-type: none"> ● Insert the operator connector again. ● Check the wiring of control circuit. ● Replace the control board or operator.

Protection function		Explanation	LCD display (English)
External baseblock signal input (Minor failure) (main circuit transistor instantance shut-off)		When an external base block signal is input, the motor coasts to a stop. When the external base block signal is removed, the inverter output is immediately turned on at the previously set frequency.	(blinking) Alarm (bb)* ¹ B.B.
Invalid parameter setting		When an invalid parameter is set, it is indicated on the monitor at power up or when the inverter is changed from the PRGM mode to the DRIVE mode.	Alarm (OPE01)* ¹ Set Cap. Error
			Alarm (OPE02)* ¹ Parameter Incorrect
			Alarm (OPE03)* ¹ I/P Term. Incorrect
			Alarm (OPE10)* ¹ V/F curve Incorrect
			Alarm (OPE11)* ¹ Carry-Freq Incorrect
Parameter read error		Parameter read error	Alarm (Err)* ¹ Read Error
RS-485 Communication Fault	Fault 1	RS-485 Communication error or transmission fault during communicating and the Rs-485 stopping method after communication error of Sn-08 is to continue to run (Sn-08=11xx)	(blinking) (CPF21)* ¹ Comm Fault 1
	Fault 2	RS-485 Communication protocol error and the RS-485 stopping method after communication error of Sn-08 is to continue to run (Sn-08=11xx)	(blinking) (CPF22)* ¹ Comm Fault 2
RS-485 Communication Ready		When the inverter with communication option card (PA-M, PA-P, PA-C or PA-L) does not receive correct data from master controller.	(CALL)* ¹ Comm Stand by

Fault Contact output	Error causes	Action to be taken
Non Operation	—	—
Non Operation	<ul style="list-style-type: none"> ● Inverter KVA setting (Sn-01) error ● Parameter setting range error ● Multi-function contact input setting error (Sn-15 ~ Sn-18) ● Improper setting of V/F characteristic (Cn-02 ~ Cn-08) ● Improper setting of carrier frequency (Cn-23 ~ Cn-25) 	<ul style="list-style-type: none"> ● Review the parameter setting range and conditions
Non Operation	<ul style="list-style-type: none"> ● EEPROM internal data did not match when initializing the constant 	<ul style="list-style-type: none"> ● Turn off power, then turn on again. If error is persistent, replace the control board.
Non Operation	<ul style="list-style-type: none"> ● RS-485 communication option card fault. ● Excess vibration or shock. ● External noise 	<ul style="list-style-type: none"> ● Turn off power, then turn on again. If error is persistent, replace the option card.
Non Operation	<ul style="list-style-type: none"> ● The RS-485 communication protocols setting in inverter (Sn-24) and option card are in consistent. 	<ul style="list-style-type: none"> ● Check the setting in Sn-24 and option card.
Non Operation	<ul style="list-style-type: none"> ● Poor connection ● Defective communication software (in master controller) 	<ul style="list-style-type: none"> ● Check for communication cable between communication option card and master controller (PLC) ● Check for communication software.